





OWNERS MANUAL

990™ AUTOLOADING SHOTGUN

IMPORTANT: “SAFETY WARNINGS” — NOTE THE SYMBOL 

THESE SAFETY WARNINGS ARE FOR YOUR PROTECTION AS WELL AS THE SAFETY OF OTHERS. DISREGARDING INFORMATION IN THIS MANUAL COULD CAUSE DEATH, SERIOUS INJURY OR PROPERTY DAMAGE TO YOU OR THOSE AROUND YOU.

 Do not attempt to load, handle or use your firearm until you read and understand the information contained in this owner's manual. Understand and follow all instructions and warnings in their entirety. Before handling your firearm, you should learn how it operates and how to maintain it. This includes knowing its basic parts, how the manual safety and other safety features operate, how to safely open and close the action, and how to safely load and unload ammunition from the firearm. Improper use and handling is dangerous and could cause death, serious injury or property damage to you or those around you. All users of the firearm must become thoroughly familiar with the instructions in this manual.

 This manual is not a comprehensive guide to firearm safety. Mossberg recommends that new firearm owners and/ or shooters seek professional training from qualified instructors prior to handling any firearm.

 Be certain this owner's manual is available for reference and is kept with this firearm if transferred to another party. If this manual is lost or misplaced, contact the Product Service Center for a free replacement copy or visit www.mossberg.com.

 After performing any work on your firearm such as cleaning, adjustments, disassembly or installation of any accessory, the firearm should be re-checked for proper functioning before using and/or firing live ammunition.

 Firearms are complex mechanisms. Any modification, alteration, or improper fitting of parts may result in a dangerous malfunction, damage to the firearm, and could cause death, serious injury or property damage to you or those around you. The firearm's owner must accept full responsibility for the correct reassembly and functioning of the firearm after any disassembly or replacement of parts.

 If you do not understand any of the material in this manual or have any questions, contact the Product Service Center or a qualified gunsmith.

O.F. MOSSBERG & SONS, INC.

P.O. BOX 497 • 7 GRASSO AVENUE, NORTH HAVEN, CONNECTICUT 06473
PHONE (800) 363-3555
www.mossberg.com

Safety and safe firearms handling is everyone's responsibility.



As the owner of a firearm, you must undertake the full-time responsibility of safe firearms handling for your own safety and the safety of those around you:

- Keep all firearms and ammunition out of the reach of children, or any unauthorized person.
- Store your firearms and ammunition separately, locked in a secure location.
- Be sure to read how to properly install your cable lock as instructed in this manual.
- Never store a loaded firearm.
- Never leave a loaded firearm unattended.
- Never transport a loaded firearm in a vehicle. When transporting your firearm, keep it unloaded, stored and secured within the confines of the vehicle.
- Unload your firearm when you have stopped shooting or when you have to climb a tree, fence or cross a slippery surface. Keeping your firearm unloaded when not in use will prevent an unintentional discharge should you accidentally slip, fall, drop or jar your firearm.
- The safety should remain fully rearward in the “ON” (SAFE) position and the firearm unloaded at all times until you are in a place where it is safe to shoot, keeping your finger off the trigger and outside the trigger guard until you are aiming at the intended target and have decided to fire.
- Never shoot at water, rocks, or any hard surfaces. Shots may glance off or ricochet off such surfaces and could cause death, serious injury or property damage to you or those around you.
- Be sure of your target and beyond. Make sure that your back stop is adequate to stop shots prior to firing.
- Do not use alcohol or drugs before or while handling firearms.
- Do not touch the trigger while the safety is being engaged or disengaged.



Remember, a firearm’s manual safety is a mechanical device which can never replace safe firearm handling practices.



Never rely on any mechanical mechanism or safety device to prevent the dangers of careless handling or pointing a firearm in an unsafe direction.



Always point the muzzle of your firearm in a safe direction, regardless of whether the firearm is loaded or unloaded. You should become thoroughly familiar with the function and operation of this firearm and the instructions supplied with it.



Always treat every firearm as if it is loaded. Give your firearm to someone with the magazine tube empty, the action open, and the safety fully rearward to the “ON” (SAFE) position, after you verify the firearm is unloaded. Insist on the same procedure when receiving a firearm from someone else. Learn the location of all the safety features of your firearm and how they operate.



Never place your finger inside the trigger guard or on the trigger unless you intend to fire. When you pull the trigger you must expect the firearm to fire and you must take full responsibility for your actions.



Always wear eye and hearing protection when firing a firearm. Firing a firearm without proper hearing protection can cause hearing loss. The use of eye protection during any type of shooting, disassembly, assembly and cleaning is important to protect your vision.



When using a firearm with mounted optics, maintain an adequate distance between the rear of the scope and your face at all times. Be certain the scope installation does not interfere with access to, or the proper functioning of the safety.



We specifically disclaim any responsibility for damage or injury whatsoever occurring in connection with, or as a result of, the use of faulty, or non-SAAMI standard, or “remanufactured”, or hand-loaded (reloaded) ammunition. Additionally, we disclaim any responsibility for damage or injury which results from any modifications or changes that are not a part of the firearm as delivered from the factory.



Check to be certain that the correct ammunition has been selected for use. Ensure it is the same gauge, length and type of shotshell as designated on the barrel. Failure to do so could cause death, serious injury or property damage to you or those around you.



Always ensure that barrel and action are clear of obstructions before firing. Firing a blocked firearm could cause death, serious injury, or property damage to you or those around you.



Never force a jammed action. This could cause a shotshell to explode resulting in death, serious injury or property damage to you or those around you.



Should any shotshell fail to fire, keep the muzzle pointed in a safe direction for at least thirty (30) seconds in case the shotshell is a “hangfire” (delayed firing of the shotshell after being struck by the firing pin). Move the safety button fully rearward to the “ON” (SAFE) position. Pull the operating handle fully rearward, extracting and ejecting the misfired shotshell. Segregate the misfired shotshell from other ammunition. Do not attempt to refire a misfired shotshell. If the indent from the firing pin is light or absent, contact a qualified gunsmith or the Product Service Center.



Do not drop, or allow anything to strike the firearm because, as with any firearm, an accidental discharge may result.



Learn to clean your firearm thoroughly and make certain no oil, grease or other materials are blocking the barrel. Obstructions of any kind can cause death, serious injury or property damage.



Practice proper firearm maintenance and safety. Make sure all exposed metal surfaces are coated with a thin film of oil, especially after being exposed to damp weather. (See the proper section of this manual for cleaning instructions.) Do not plug the barrel or store in a fabric-lined case, which will absorb lubricants from the firearm. Always store this firearm with the chamber empty and magazine tube unloaded. Failure to do so could result in an unintentional discharge.



Before using the firearm after storage, follow complete instructions stated in this manual for re-familiarization with the firearm. A thorough inspection and function test should be performed before going into the field. Have your firearm periodically checked by a qualified gunsmith.



STATE-BY-STATE WARNINGS

Certain states require, by law, that their own specified warning notices, in larger-than-normal type be conspicuously included by the manufacturer, distributor, or retail dealer with firearms sold in that state. O.F. Mossberg & Sons, Inc. ("Mossberg") sells its products in compliance with applicable laws and regulations. Because our products may be sold in these states, we include the following:



CALIFORNIA:

Firearms must be handled responsibly and securely stored to prevent access by children and other unauthorized users. California has strict laws pertaining to firearms, and you may be fined or imprisoned if you fail to comply with them. Visit the Web site of the California Attorney General at <https://oag.ca.gov/firearms> for information on firearm laws applicable to you and how you can comply. Prevent child access by always keeping guns locked away and unloaded when not in use. If you keep a loaded firearm where a child obtains and improperly uses it, you may be fined or sent to prison.



ADVERTENICA:

Las armas de fuego deben manipularse de manera responsable y segura para evitar el acceso de niños y otros usuarios no autorizados. California tiene leyes estrictas relacionadas con armas de fuego, y usted puede ser multado o encarcelado si no las cumple. Visite la pagina web del Procurador General de California en <https://oag.ca.gov/firearms> para obtener información sobre las leyes de armas de fuego que le son aplicables y cómo puede cumplirlas. Evite el acceso de niños manteniendo siempre las armas bloqueadas y descargadas cuando no estén en uso. Si mantiene un arma de fuego cargada donde un niño obtiene y la usa indebidamente, se le puede multar o enviar a prisión.



CONNECTICUT:

"UNLAWFUL STORAGE OF A LOADED FIREARM MAY RESULT IN IMPRISONMENT OR FINE."



**FLORIDA:**

“IT IS UNLAWFUL, AND PUNISHABLE BY IMPRISONMENT AND FINE, FOR ANY ADULT TO STORE OR LEAVE A FIREARM IN ANY PLACE WITHIN THE REACH OR EASY ACCESS OF A MINOR UNDER 18 YEARS OF AGE OR TO KNOWINGLY SELL OR OTHERWISE TRANSFER OWNERSHIP OR POSSESSION OF A FIREARM TO A MINOR OR A PERSON OF UNSOUND MIND.”

**MAINE:**

“ENDANGERING THE WELFARE OF A CHILD IS A CRIME. IF YOU LEAVE A FIREARM AND AMMUNITION WITHIN EASY ACCESS OF A CHILD, YOU MAY BE SUBJECT TO FINE, IMPRISONMENT OR BOTH. KEEP FIREARMS AND AMMUNITION SEPARATE. KEEP FIREARMS AND AMMUNITION LOCKED UP. USE TRIGGER LOCKS.”

**MARYLAND:**

“WARNING: Children can operate firearms which may cause death or serious injury. It is a crime to store or leave a loaded firearm in any location where an individual knew or should have known that an unsupervised minor would gain access to the firearm. Store your firearm responsibly!”

**MASSACHUSETTS:**

“WARNING FROM THE MASSACHUSETTS ATTORNEY GENERAL: This handgun is not equipped with a device that fully blocks use by unauthorized users.

More than 200,000 firearms like this one are stolen from their owners every year in the United States. In addition, there are more than a thousand suicides each year by younger children and teenagers who get access to firearms. Hundreds more die from accidental discharge. It is likely that many more children sustain serious wounds, or inflict such wounds accidentally on others. In order to limit the chance of such misuse, it is imperative that you keep this weapon locked in a

secure place and take other steps necessary to limit the possibility of theft or accident. Failure to take reasonable preventative steps may result in innocent lives being lost, and in some circumstances may result in your liability for these deaths.”

“IT IS UNLAWFUL TO STORE OR KEEP A FIREARM, RIFLE, SHOTGUN OR MACHINE GUN IN ANY PLACE UNLESS THAT WEAPON IS EQUIPPED WITH A TAMPER RESISTANT SAFETY DEVICE OR IS STORED OR KEPT IN A SECURELY LOCKED CONTAINER.”



NEW JERSEY:

“IT IS A CRIMINAL OFFENSE TO LEAVE A LOADED FIREARM WITHIN EASY ACCESS OF A MINOR.”



NEW YORK CITY:

“THE USE OF A LOCKING DEVICE OR SAFETY LOCK IS ONLY ONE ASPECT OF RESPONSIBLE WEAPON STORAGE. ALL WEAPONS SHOULD BE STORED UNLOADED AND LOCKED IN A LOCATION THAT IS BOTH SEPARATE FROM THEIR AMMUNITION AND INACCESSIBLE TO CHILDREN AND ANY OTHER UNAUTHORIZED PERSONS. NEW YORK CITY LAW PROHIBITS, WITH CERTAIN EXCEPTIONS, ANY PERSON FROM ACQUIRING MORE THAN ONE FIREARM, OR MORE THAN ONE RIFLE OR SHOTGUN, WITHIN A 90-DAY PERIOD.”



NORTH CAROLINA:

“IT IS UNLAWFUL TO STORE OR LEAVE A FIREARM THAT CAN BE DISCHARGED IN A MANNER THAT A REASONABLE PERSON SHOULD KNOW IS ACCESSIBLE TO A MINOR.”

Any person who resides in the same premises as a minor, owns or possesses a firearm, and stores or leaves the firearm (i) in a condition that the firearm can be discharged and (ii) in a manner that the person knew or should have known that an unsupervised minor would be able to gain access to the firearm, is guilty of a Class 1 misdemeanor if

a minor gains access to the firearm without the lawful permission of the minor's parents or a person having charge of the minor and the minor:

- (1) Possesses it in violation of G.S. 14-269.2(b);
- (2) Exhibits it in a public place in a careless, angry, or threatening manner;
- (3) Causes personal injury or death with it not in self defense; or
- (4) Uses it in the commission of a crime.



TEXAS:

“IT IS UNLAWFUL TO STORE, TRANSPORT, OR ABANDON AN UNSECURED FIREARM IN A PLACE WHERE CHILDREN ARE LIKELY TO BE AND CAN OBTAIN ACCESS TO THE FIREARM.”



WISCONSIN:

“IF YOU LEAVE A LOADED FIREARM WITHIN THE REACH OR EASY ACCESS OF A CHILD YOU MAY BE FINED OR IMPRISONED OR BOTH IF THE CHILD IMPROPERLY DISCHARGES, POSSESSES, OR EXHIBITS THE FIREARM.”



A note about the warnings and information contained in this manual:

The above warnings are not intended to be exhaustive. We strongly suggest that you check with your local licensed retailer or state police for additional information concerning firearms ownership, or hunting or target shooting rules that may be required by local law or regulation. Since such rules and regulations are subject to change, local authorities are in the best position to advise you on such matters.

TABLE OF CONTENTS

| | Page |
|---|------------|
| Operating Instructions/ The Mechanical Safety | 9-10 |
| The Cocking Indicator | 11 |
| Unpacking Your Firearm | 11 |
| Opening the Action | 12 |
| Closing the Action | 13 |
| Magazine Capacity | 13 |
| Loading the Firearm | 13-14 |
| Loading the Magazine Tube | 15 |
| Firing | 16-17 |
| To Clear A Malfunction ("Jam") | 18 |
| Unloading the Firearm | 19 |
| Disassembly | 20-22 |
| Cleaning and Lubrication | 23-24 |
| Re-Assembly | 25-27 |
| Function Testing | 28 |
| Sights | 29 |
| Stock Spacer System | 30 |
| Choke Tubes..... | 31 |
| Storage | 32 |
| Cable Lock | 33 |
| Service Instructions | 34 |
| Warranty Information | 35-36 |
| 990™ Autoloading Shotgun Exploded View Parts List | 37 |
| 990™ Autoloading Shotgun Exploded View | 38 |
| Notes | 39 |
| <i>The Basic Rules of Safe Firearms Handling</i> | Back Cover |



WARNING: This product can expose you to chemicals, including lead, which is known to the State of California to cause cancer and birth defects or other reproductive harm. For more information go to www.P65Warnings.ca.gov.



OPERATING INSTRUCTIONS



Read and understand this entire manual and its safety warnings before handling this firearm.

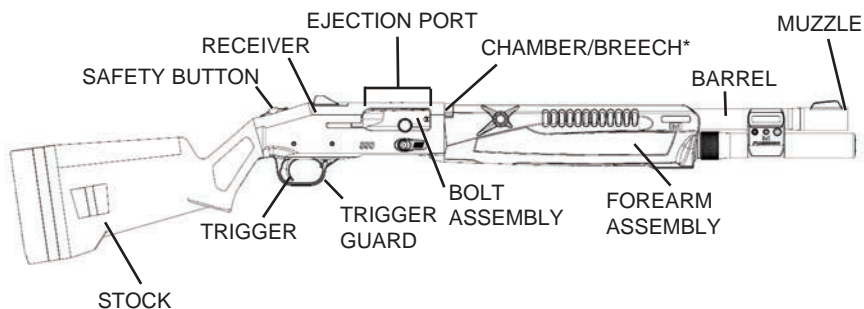

990™ AUTOLOADING SHOTGUN

*The chamber is the rearmost part of the inside of the barrel. The breech is the rear face of the barrel. They can only be seen when the bolt is in the “open” position.

MECHANICAL SAFETY

The safety button is located on the top rear portion of the receiver (Figure 1) and must be manually moved to the desired position by the shooter.

To put the safety in the “ON” (SAFE) position, the safety button must be moved fully rearward into the safety detent. The button will now cover the red dot. The red dot is a training aid used only to show the direction of the “ON” (SAFE) position and should not be used as an indicator that the safety is “ON” or “OFF.” Moving the safety button forward toward the muzzle of the firearm will put the safety in the “OFF” (FIRE) position.



Remember, a firearm’s manual safety is a mechanical device which can never replace safe firearm handling practices.



Never rely on any mechanical mechanism or safety device to prevent the dangers of careless handling or pointing a firearm in an unsafe direction.

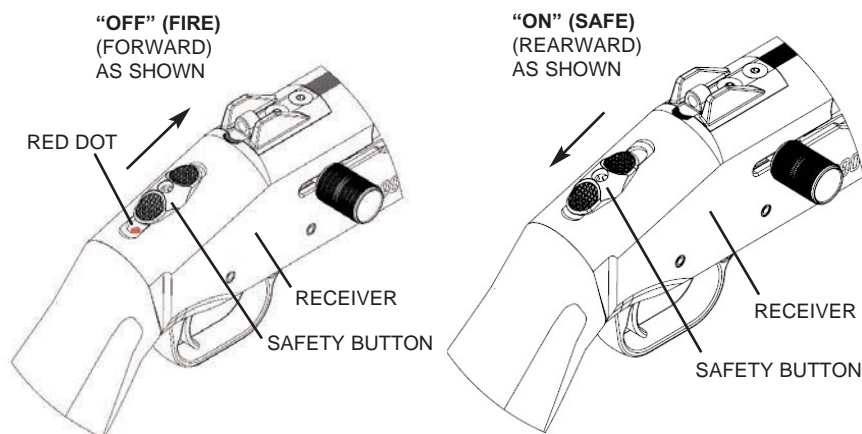

Figure 1



Keep your finger off the trigger and outside of the trigger guard until you are aiming at the intended target and have decided to fire. The safety should remain fully rearward to the “ON” (SAFE) position and the firearm unloaded at all times until you are in a place where it is safe to shoot.



Placing the safety in an intermediate position between the “ON” and “OFF” position can result in the user thinking the firearm is in a SAFE or FIRE position when it is not. Pulling the trigger with the safety in an intermediate position may cause the firearm to fire. Therefore, always move the safety fully to its intended position, “ON” or “OFF”, and then check to be sure it is where you want it to be. Never attempt to fire the firearm with the safety only partially engaged, as the firearm may discharge and could result in death, serious injury or property damage.

COCKING INDICATOR

Your firearm is equipped with a cocking indicator located in the forward section of the trigger guard (Figure 2). The cocking indicator allows the shooter to know whether or not the firearm is cocked. When the firearm is cocked (ready to fire), the indicator will protrude into the trigger guard. The cocking indicator is an automatic device; it cannot be manually activated or deactivated.



The cocking indicator is not a safety and does not indicate whether or not a shotshell is in the chamber. You must visually and physically inspect the chamber, elevator and magazine tube to determine if the firearm is loaded.



Remember, the firearm's cocking indicator is a mechanical device which can never replace safe firearm handling practices.



Never rely on any mechanical mechanism or safety device to prevent the dangers of careless handling or pointing a firearm in an unsafe direction.

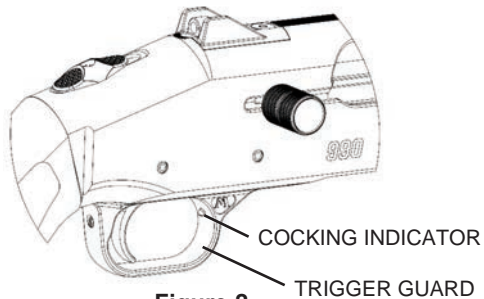

Figure 2

UNPACKING YOUR FIREARM

NOTE: Your firearm may come with a rubber cap installed over the operating handle to protect packaging during shipping. Remove this cap when unpacking your firearm.

Your firearm is shipped from the factory fully assembled. Before using this firearm, gently tug outward on the operating handle to ensure it is securely engaged in the bolt. If the operating handle should come out of the bolt, please refer to the Action Re-assembly instructions. The operating handle must be properly installed prior to use. A bright orange chamber plug has been inserted in the chamber (Figure 3) as an aide to ensure that the chamber is unloaded. You must remove this plug prior to use.

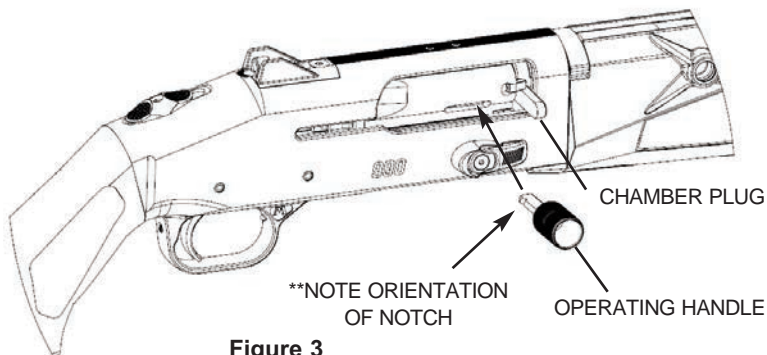

Figure 3

OPENING THE ACTION



Ensure the safety button is fully rearward in the “ON” (SAFE) position (Figure 1). Visually and physically check the chamber, elevator, and magazine tube to be sure the firearm is unloaded. Keep the muzzle pointed in a safe direction at all times.

NOTE: The action is comprised of the bolt assembly, slide assembly, and operating handle.

1. With the safety button fully rearward in the “ON” (SAFE) position, and the muzzle pointed in a safe direction, hold the firearm in your left hand by the forearm assembly, and grasp the operating handle with your right hand.
2. Pull the operating handle fully rearward in one quick motion. When released, the bolt will move slightly forward (towards the muzzle) and lock in the open position. (Figure 4).
3. Remove the chamber plug from the chamber. It is recommended that the chamber plug be reinstalled when the firearm is not in use as an added measure of safety to indicate the chamber is unloaded.

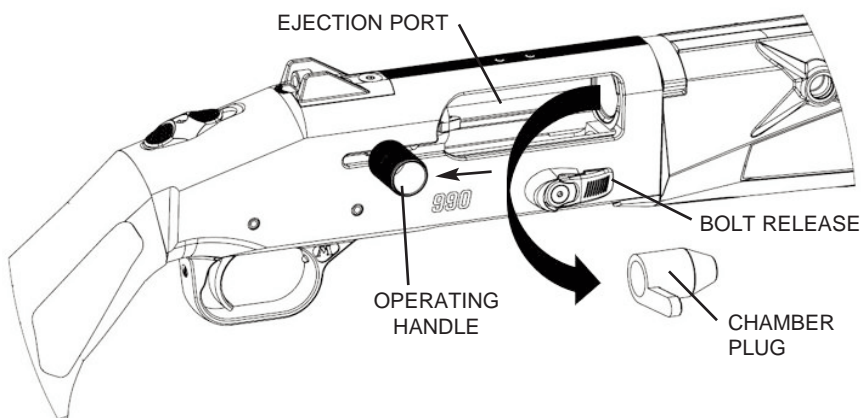

Figure 4



The bolt is always under spring pressure. When the bolt release is pushed with the bolt locked rearward, the bolt is driven forward toward the ejection port or near the operating handle. Do not have fingers or other objects in the ejection port or near the operating handle.



Visually and physically inspect the chamber and bore of the barrel to make certain it is free of any obstructions, excessive oil or grease. If you are unable to remove any obstruction, bring the firearm to a qualified gunsmith or send it to a factory authorized Product Service Center. Obstructions of any kind could cause death, serious injury or property damage to you or those around you when the firearm is fired.



CLOSING THE ACTION



Keep fingers clear of the operating handle and the ejection port when closing the action. (Figure 4)

With the safety button fully rearward in the "ON" (SAFE) position, and the muzzle pointed in a safe direction, press the bolt release until the action releases (Figure 4).

MAGAZINE CAPACITY



As a firearms owner you are responsible for complying with all applicable laws, including but not limited to any state or local restrictions regarding magazine capacity. Check with your local retailer or state police for laws that may be applicable to you, including but not limited to magazine capacity. Since such regulations are subject to change, state and local authorities are in the best position to advise you on such matters.

Total ammunition capacity (including one in the chamber) is eight (8) 2-3/4" shotshells (Seven (7) in the magazine tube, plus one (1) in the chamber).

Depending upon shotshell variations, total capacity may be reduced by one shotshell.

LOADING THE FIREARM



WARNING: This product can expose you to chemicals, including lead, which is known to the State of California to cause cancer and birth defects or other reproductive harm. For more information go to www.P65Warnings.ca.gov.

The 990™ model is designed to fire 12 gauge 2-3/4" factory loaded shotshells and 3" factory loaded magnum shotshells.



Before loading, move the safety button fully rearward to the "ON" (SAFE) position (Figure 1).



Before loading, visually and physically inspect the chamber and bore of the barrel for any obstruction, excessive oil or grease (the chamber is the rearmost part of the inside of the barrel). Obstructions of any kind could cause death, serious injury, or property damage to you or those around you.



During loading, never allow fingers or any other objects to contact the trigger. Keep the muzzle pointed in a safe direction at all times.



Do not load the firearm until ready for use! Unload the firearm when shooting has been completed! The safety button should always be fully rearward in the "ON" (SAFE) position whether or not the firearm is loaded.



Check to be certain that the correct ammunition has been selected for use. Ensure it is the same gauge, length and type of shotshell as designated on the barrel. Failure to do so could cause death, serious injury or property damage to you or those around you.



Always inspect your ammunition before using it. Never use dirty, corroded or damaged ammunition. A shotshell failure could cause death, serious injury or property damage to you or those around you.



Use only new commercially manufactured ammunition which is in strict accordance with the standards of the Sporting Arms and Ammunition Manufacturers' Institute (SAAMI). If you are uncertain, contact your ammunition supplier for verification.



1. Hold the firearm in your left hand by the forearm assembly and grasp the operating handle with your right hand. Open the action by pulling the operating handle completely rearward until it locks in the open position.
2. Load the first shotshell through the ejection port located on the right side of the receiver. The shotshell can be inserted directly into the chamber or placed on top of the elevator (Figure 5).



Because the bolt is under considerable spring pressure, Keep fingers clear of the operating handle and the ejection port when closing the action.

3. With the safety button fully rearward in the "ON" (SAFE) position, and the muzzle pointed in a safe direction, press the bolt release until the action releases (Figure 5).
4. The action will close under spring force, chambering a live shotshell. **Be sure to keep fingers and other objects out of the ejection port!**



The firearm is now loaded and will fire if the safety is moved to the "OFF" (FIRE) position and the trigger is pulled! The safety button (Figure 1) should be kept fully rearward in the "ON" (SAFE) position until you are on target and have actually decided to fire. Keep the muzzle pointed in a safe direction at all times, and your fingers and any other objects away from the trigger area.

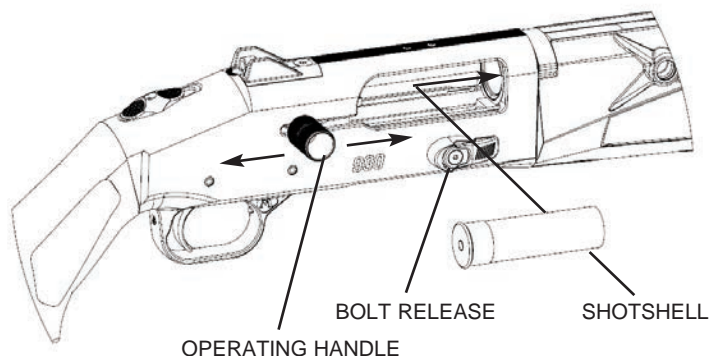

Figure 5

LOADING THE MAGAZINE TUBE



With the safety button fully rearward in the “ON” (SAFE) position, and the bolt in the forward (closed) position, hold the firearm with the trigger guard facing upward. **Keep the muzzle pointed in a safe direction at all times.**

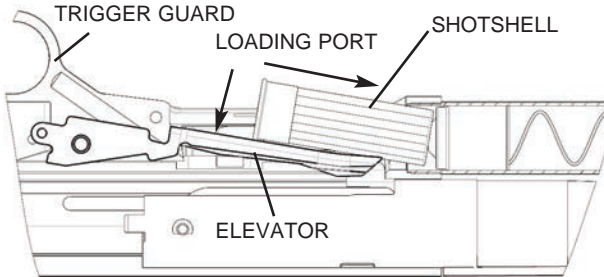

Figure 6

1. Carefully push the shotshell into the loading port, depressing the elevator (Figure 6). This will expose the magazine tube opening within the receiver.
2. Continue carefully pushing the shotshell into the magazine tube until the rim of the shotshell is past the shell stop (Figure 7). The shell stop will “snap” over the rim of the shotshell. Repeat this sequence to load each additional shotshell.

If the shotshell is not pushed all the way into the magazine tube, it will pop back out on the opposite side of the elevator. If this should occur, while keeping the muzzle pointed in a safe direction, simply open the action by pulling the operating handle rearward, ejecting the shotshell from the chamber. Releasing the operating handle will allow the action to close, automatically feeding the “misloaded” shotshell into the chamber.



The firearm is now loaded and will fire if the safety is moved to the “OFF” (FIRE) position and the trigger is pulled! The safety button (Figure 1) should be kept fully rearward in the “ON” (SAFE) position until you are on target and have actually decided to fire. Keep the muzzle pointed in a safe direction at all times, and your fingers and any other objects away from the trigger area.

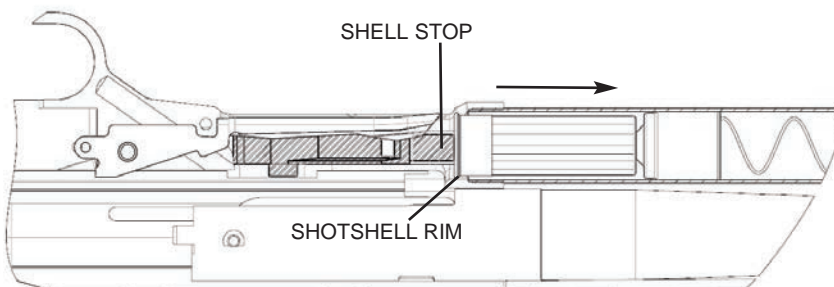

Figure 7



FIRING



Use of this product, including discharging firearms in poorly ventilated areas, cleaning firearms, or handling ammunition can result in exposure to chemicals, including lead, which are known to the state of California to cause serious physical injury, including cancer, birth defects or other reproductive harm. For more information, go to www.P65Warnings.ca.gov.



Have adequate ventilation at all times and wash hands thoroughly after exposure.



During firing, the operating handle travels rearward with considerable force and speed. Do not place hands or other objects in its path.



Always wear eye and hearing protection when firing a firearm. Firing a firearm without proper hearing protection can cause hearing loss. The use of eye protection during any type of shooting, disassembly, assembly and cleaning is important to protect your vision.



Be sure of your target and beyond. Make sure that your back stop is adequate to stop shots prior to firing.



When you pull the trigger you must expect the firearm to fire and you must take full responsibility for your actions.



Always ensure that barrel and action are clear of obstructions before firing. Firing a blocked firearm could cause death, serious injury, or property damage to you or those around you.



Do not attempt to remove a bore obstruction using a blank shotshell, or a shell from which the shot charge has been removed, or by shooting it out with another shotshell.

With the muzzle pointed in a safe direction and the firearm held in the proper firing position, move the safety button fully forward to the "OFF" (FIRE) position (Figure 1). Pulling the trigger through its full travel to the rear will fire the firearm. Ensure the muzzle is pointed in a safe direction before placing your finger on the trigger.



After firing, the empty shotshell will be automatically ejected through the ejection port. Be sure all observers are clear of the path of ejection, as the empty shotshells are thrown out with considerable force and could cause injury.



This firearm automatically feeds the next live shotshell from the magazine tube into the chamber each time the firearm is fired, until all shotshells in the magazine tube are fired. You should be aware that no mechanical force on the part of the user is needed in this process and you should be alert to the fact that the chamber is loaded for you and the firearm is capable of firing again if the trigger is pulled.



This firearm is designed so that when all shotshells have been fired, the bolt will automatically lock rearward in the open position. You should never use this feature as a guide for determining if the firearm is empty! Always visually and physically inspect the chamber, elevator, and magazine tube for the presence of ammunition to ensure the firearm is completely unloaded.





Should any shotshell fail to fire, keep the muzzle pointed in a safe direction for at least thirty (30) seconds in case the shotshell is a “hangfire” (delayed firing of the shotshell after being struck by the firing pin). Move the safety button fully rearward to the “ON” (SAFE) position. Pull the operating handle fully rearward, extracting and ejecting the misfired shotshell. Segregate the misfired shotshell from other ammunition. Do not attempt to refire a misfired shotshell. If the indent from the firing pin is light or absent, contact a qualified gunsmith or the Product Service Center.



If at any time during firing, the sound of any shotshell is noticeably louder or softer than previous shotshells fired, STOP! Do not load or fire additional shotshells. Move the safety button fully rearward to the “ON” (SAFE) position. Keep the muzzle pointed in a safe direction and, while keeping the ejection port and loading port opening of the firearm turned away from your face (to protect your eyes in the event a defective shotshell explodes). Safely unload your firearm as instructed in the Unloading the Firearm section of this owner’s manual. Remove the barrel as instructed in the Disassembly section of this owner’s manual. Inspect the barrel and firearm for possible damage or obstructions to the chamber or bore. Firing the firearm with a bore obstruction can cause damage to the firearm and could cause death, serious injury, or property damage to you or those around you.



Some brands of ammunition may cause difficulty in extracting spent shotshell cases from the chamber. If this situation occurs, thoroughly clean the chamber with solvent (refer to Cleaning And Lubrication section of this owner’s manual). If this condition persists, we recommend you change to another brand of ammunition.



Use only new commercially manufactured ammunition which are in strict accordance with the standards of the Sporting Arms and Ammunition Manufacturers’ Institute (SAAMI). If you are uncertain, contact your ammunition supplier for verification.

NOTE: Recommended live fire break-in period for the model 990™ is 50 rounds of commercially manufactured 2-3/4”, 12 ga. ammunition, with a payload of 1-1/8 oz., and a velocity of 1200 feet per second or higher. Once the break-in period is completed, the model 990™ will reliably cycle with 1-1/8 oz. light target factory loads with a velocity of 1145 feet per second or higher. A break-in period is not required for shooting 2-3/4” buckshot or slug loads.



All auto-loading firearms may occasionally experience a malfunction (jam) related to the feeding of ammunition. If a shotshell jams, do not attempt to force it into the chamber. Carefully remove it by following steps 1-5 in the To Clear A Malfunction (“Jam”) section of this owner’s manual. Most malfunctions are caused by improper ammunition, an improper grip on the firearm when firing, or improper lubrication. To help minimize the chance of malfunctions (jams), regularly perform cleaning/preventative maintenance on your firearm pursuant to the instructions in this manual. If you experienced a malfunction (jam) while using a new brand, type or lot of ammunition, try firing another type of ammunition to determine whether the ammunition was the source of the malfunction (jam).



TO CLEAR A MALFUNCTION (“JAM”)

1. Always keep the muzzle pointed in a safe direction. Keep your finger off the trigger and outside the trigger guard. Ensure the safety is fully rearward in the “**ON**” (**SAFE**) position, and that you are wearing proper eye and hearing protection.
2. Unload the firearm (Refer to Unloading section of this owner’s manual).
3. Lock the action in the open position (Refer to Opening the Action section of this owner’s manual).
4. Visually and physically inspect the chamber, elevator and magazine tube to be certain the firearm is unloaded, and that the shotshell that was stuck has been ejected during this process. If the shotshell has ejected and there is no jam, then properly clean the firearm as instructed in this manual and try different ammunition. You may now resume normal operation. If you still experience a jam, contact a qualified gunsmith or the Product Service Center.
5. If a shotshell is stuck in the chamber and does not eject after the above steps, or you experience a possible bore obstruction then do not attempt to close the action. Remove the barrel (refer to the Disassembly section of this owner’s manual). Contact a qualified gunsmith so that the gunsmith may remove the shotshell and/or bore obstruction and verify there is no damage to the firearm.



Do not attempt to remove a bore obstruction using a blank shotshell, or a shell from which the shot charge has been removed, or by shooting it out with another shotshell.



Never force a jammed action. This could cause a shotshell to explode resulting in death, serious injury or property damage to you or those around you.



Do not use a metal tool to attempt to remove an unfired shotshell because it could ignite the primer and fire or rupture sending fragments out of the ejection port with sufficient force that could cause death, serious injury or property damage to you or those around you.



Never pull the trigger if the bolt does not fully close to prevent a possible out of battery firing. If this happens, unload the firearm (refer to Unloading the Firearm section of this owner’s manual). Examine the shotshell that was in the chamber and check the chamber to ensure that there are no obstructions or debris in it.



UNLOADING THE FIREARM



WARNING: This product can expose you to chemicals, including lead, which is known to the State of California to cause cancer and birth defects or other reproductive harm. For more information go to www.P65Warnings.ca.gov.



Set the safety button fully rearward to the "ON" (SAFE) position. During unloading, never allow your fingers or any other object to contact the trigger. **KEEP THE MUZZLE POINTED IN A SAFE DIRECTION AT ALL TIMES.**

1. First, remove the shotshells from the magazine tube. With the safety button fully rearward in the "ON" (SAFE) position, turn the firearm so that the trigger guard is facing upward (Figure 8).
2. Keeping the muzzle pointed in a safe direction, depress the elevator (Figure 8).
3. While holding the elevator down with your thumb, press and release the shell stop (Figure 8). This will release one shotshell from the magazine tube under spring pressure.
4. Repeat this procedure until the magazine tube is empty.
5. With the magazine tube empty, turn the firearm so that the trigger guard is facing downward, keeping the muzzle pointed in a safe direction, pull the operating handle fully rearward (Figure 9). This will eject the shotshell from the chamber of the firearm and lock the action in the "OPEN" position.



After unloading always visually and physically inspect the chamber, elevator, and magazine tube to be certain all of the shotshells have been removed, and the firearm is completely unloaded.

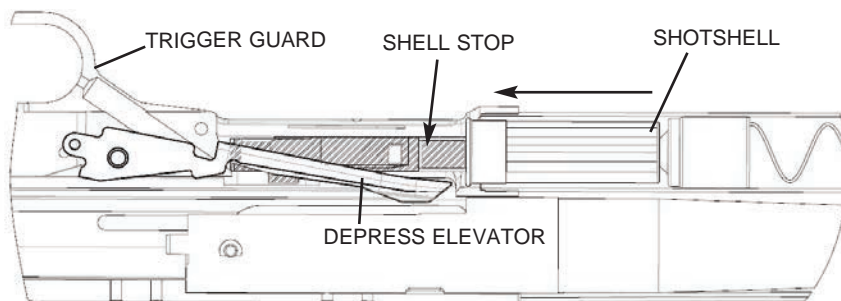

Figure 8

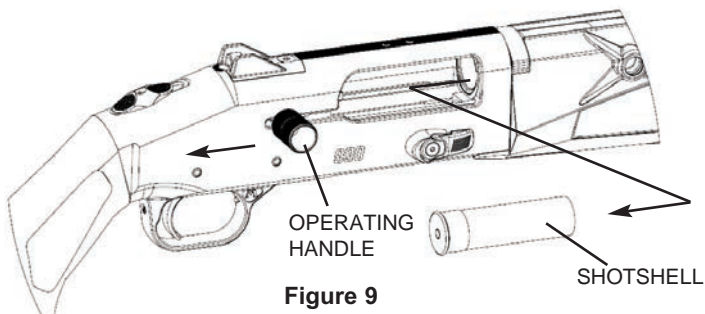

Figure 9

DISASSEMBLY



Before disassembling the firearm, set the safety button fully rearward to the "ON" (SAFE) position and keep the muzzle pointed in a safe direction. Lock the action open, visually and physically check the chamber, elevator, and magazine tube to ensure the firearm is completely unloaded (Refer to the Unloading The Firearm section of this owner's manual).



Wear eye protection during disassembly and cleaning to protect your eyes from oil spatter or spring loaded components.

BARREL REMOVAL

The action must be in the open position (bolt fully rearward). (See "Opening The Action" section.)

1. Remove the barrel clamp. Using a 5/32" allen key to remove the screws (one each side). Remove the two halves of the barrel clamp. Note orientation for re-assembly.
2. Unscrew the magazine tube sleeve (Figure 10A).
3. Slide the forearm assembly forward. Once halfway down the magazine tube, remove the handguard band by sliding it rearward off the forearm assembly. Continue to slide the forearm assembly forward until free of the magazine tube.

NOTE: Failure to remove the handguard band prior to fully removing the forearm assembly may cause damage to your front sight.

4. Pull the barrel forward, free of the receiver and magazine tube. Ensure the gas piston remains in the gas cylinder or the barrel will bind (Figure 10A).

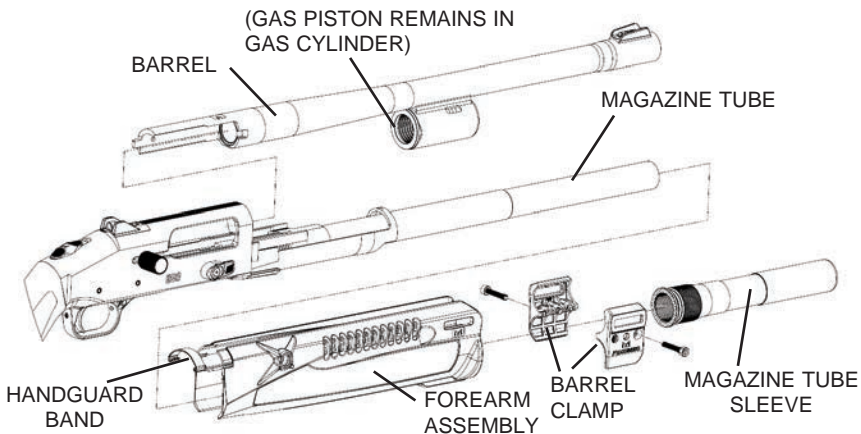

GAS SYSTEM COMPONENT REMOVAL

Remove the gas piston assembly from the gas cylinder (Figure 10B). To remove the bolt assembly and slide assembly see Action Removal/Disassembly section of this owners manual.

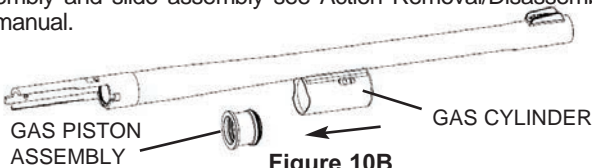

GAS PISTON DISASSEMBLY

1. Use a small flat head screwdriver to remove the retaining ring (Figure 11A). Engage the screwdriver blade in the retaining ring notch to pry the ring out of the groove.
2. Insert the screwdriver blade under the retaining ring and move it around the piston clockwise to pry the ring off the piston.
3. With the retaining ring removed, slide the outer piston rings off the piston (Figure 11B).

NOTE: The gas piston assembly has an inner piston ring (Figure 11A) installed by the factory. This inner ring should not be removed during disassembly or cleaning.

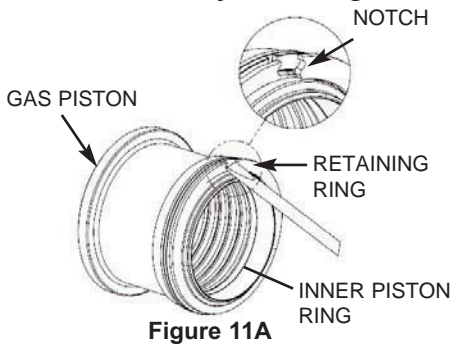

Figure 11A

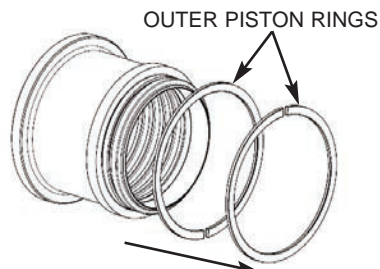

Figure 11B

TRIGGER HOUSING REMOVAL

1. Holding the operating handle, press the bolt release (Figure 5) and slowly release the bolt manually.
2. Push out the two trigger housing retaining pins using a punch no larger than 1/8" diameter (Figure 12). (The pins can be pushed out from either direction).
3. Remove the trigger housing assembly by pulling it straight out of the receiver.

The trigger housing assembly is a complex assembly and must not be disassembled. Disassembly should only be performed by the Product Service Center or a qualified gunsmith.



Never pull the trigger while the trigger housing assembly is removed from the receiver, as personal injury or damage to the trigger housing assembly may result.

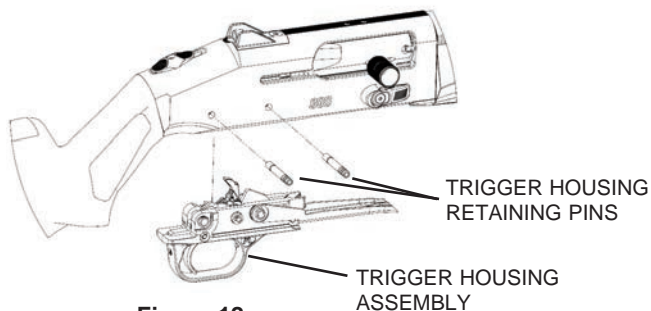

Figure 12

ACTION REMOVAL/DISASSEMBLY



Wear eye protection during disassembly and cleaning to protect your eyes from oil spatter or spring loaded components.



The action spring is under considerable pressure. It is recommended to keep the slide assembly on the magazine tube when disassembling and cleaning for easier reassembly.

1. Ensure the bolt is closed. Pull the operating handle straight out of the bolt assembly (Figure 13).
2. While pressing the bolt release, slide out the bolt assembly, slide assembly and piston stop from the receiver through the opening for the barrel, leaving them on the magazine tube.
3. Remove the bolt assembly from the slide. No further disassembly is required.

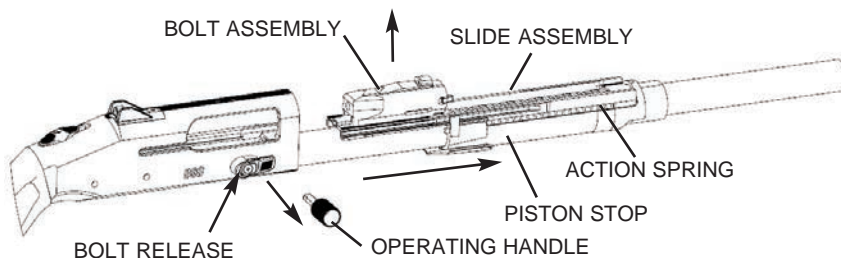

Figure 13

MAGPUL® SGA® STOCK REMOVAL



Before removing or installing an accessory on your firearm, set the safety button fully rearward to the "ON" (SAFE) position and keep the muzzle pointed in a safe direction. Open the action, visually and physically check the chamber, elevator, and magazine tube to ensure the firearm is completely unloaded (Refer to the Unloading The Firearm section of this owner's manual).

1. Using a small screwdriver, remove the thumb strip from the rear of the stock as shown in Figure 14.
2. Using a 1/4" allen key, remove the bolt.
3. Pull the stock off the receiver. Remove the receiver plate.

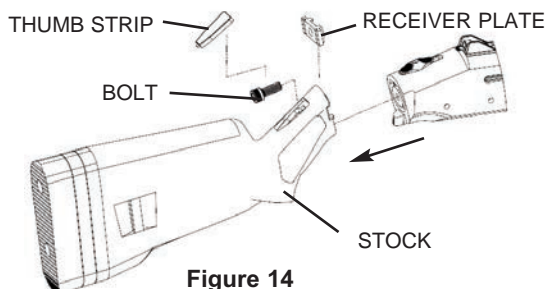

Figure 14



Field disassembly is now complete. Further disassembly should only be performed by a qualified gunsmith or the Product Service Center. Improper disassembly or reassembly, alterations, modifications and/or repairs by a party other than Mossberg could compromise the safety or performance of your firearm, and could result in death, serious injury, or property damage to you or others and will void your warranty.

CLEANING AND LUBRICATION

With proper maintenance and care, your firearm will provide you with years of dependable service. Your firearm should be inspected and cleaned periodically to ensure that it remains in good condition. Clean and lubricate your firearm as soon as possible after use. This is especially important if your firearm has been exposed to moisture. For maximum performance and continued satisfaction with your firearm, periodic cleaning and lubrication are essential. Wear eye protection during cleaning.

To clean and lubricate your firearm, first disassemble it (refer to the Disassembly section of this owner's manual). Use the instructions and equipment provided with a quality firearm cleaning kit as well as the instructions in this owner's manual.



Always be sure that the firearm is unloaded (refer to the Unloading section of this owner's manual) by visually and physically checking the chamber, elevator and magazine tube before cleaning your firearm. Be sure that the safety is fully rearward to the "ON" (SAFE) position. Wear eye protection during cleaning and assembly to protect your eyes from oil splatter and spring loaded components.



Always make sure that no ammunition is located in the area where you clean your firearm. Cleaner-lubricant-preservative can affect the primer and powder in ammunition and cause it to malfunction. This could result in a shotshell being pushed into the barrel of your firearm and getting stuck. Firing another round with a shotshell stuck in the barrel could cause the barrel to burst and result in death, serious injury, or property damage to you or those around you.



WARNING: This product can expose you to chemicals, including lead, which is known to the State of California to cause cancer and birth defects or other reproductive harm. For more information go to www.P65Warnings.ca.gov.

Normal use requires only that the mechanisms be free of excessive shooting residue. All metal parts should be cleaned with an appropriate firearm cleaning solvent. Very little lubrication other than a light oiling of internal and external surfaces to prevent rust is needed. Use only lubricants specifically designed for firearms. Avoid the use of abrasives which may damage the metal finish.

To ensure optimum performance, Mossberg recommends thorough cleaning of your firearm after every 500 rounds. However, unusually dusty, dirty, or harsh weather conditions, or use of ammunition which leaves significant powder residue may require more frequent cleaning.

If the firearm is to be stored for a long period of time, it should be thoroughly cleaned and oiled. Do not plug the barrel or store in a fabric-lined case that will absorb lubricant from the firearm, as this may result in corrosion to the unprotected metal surfaces.

Over-lubrication should be avoided during below freezing conditions. Many lubricants thicken in low temperatures which could affect the operation of the firearm. Exposure to unfavorable weather, or moisture from condensation, requires additional care to prevent corrosion of the firearm.

BARREL CLEANING

Scrub the bore and chamber with solvent and follow with cleaning patches until the barrel is clean. A final pass with a lightly oiled patch will provide a protective coating. A stiff brass bristle brush is useful for removing stubborn deposits.



Make sure the barrel is free of obstructions and excessive lubricant after cleaning. Be sure not to leave cleaning patches, excessive oil or grease in the bore. Obstructions of any kind can cause damage to the firearm and could cause death, serious injury, or property damage to you or those around you.

ACTION CLEANING



The action spring is under considerable pressure. It is recommended to keep the slide assembly on the magazine tube when disassembling and cleaning for easier reassembly.

Using a solvent, clean all components of the action including the bolt and slide assemblies (Figure 13) to remove accumulated residue. Using a rag, remove any deposits from the piston stop. Action parts will remain cleaner, longer, if lubrication is used sparingly.

RECEIVER CLEANING

Clean the inside of the receiver with a rag or soft bristle brush, giving special attention to the tracks which guide the bolt and slide. Place a few drops of light oil in these tracks when clean. Care should be taken when cleaning the exterior surfaces of the receiver to prevent cosmetic damage. Never use a brush with metal bristles, as this could remove the protective coating on the receiver.

TRIGGER HOUSING CLEANING

Brush loose residue from the trigger housing with a soft bristle brush. Never use a brush with metal bristles, this may damage the trigger housing.



Never pull the trigger while the trigger housing is removed from the receiver, as personal injury or damage to the trigger housing may result.

GAS SYSTEM COMPONENT CLEANING

The gas system includes the magazine tube, gas piston assembly and gas cylinder portion of the barrel (Figure 10A and 10B). These parts should be thoroughly cleaned using a solvent. A stiff brass bristle brush is useful for removing stubborn deposits on the gas piston assembly, magazine tube and gas cylinder.

Using a rag and solvent, remove deposits from the magazine tube.

Using a stiff brass bristle brush and solvent, remove deposits from the inside and outside of the outer gas rings and the gas piston. It is critical that these components are free of deposits to ensure proper function of your firearm.

NOTE: The gas piston assembly has an inner piston ring installed by the factory. This inner ring should not be removed during disassembly or cleaning. After cleaning ensure inner piston ring can rotate freely.

Using a stiff brass bristle brush and solvent, thoroughly clean the inside of the gas cylinder portion of the barrel, making sure to remove all deposits to ensure that the gas piston assembly is able to reciprocate freely through its full range of travel.

Apply a light coat of gun oil to all metal parts and then wipe thoroughly with a dry cloth. Excess oil will accelerate the build up of carbon residue in the gas system and may have a negative effect on the firearm's performance.

Camouflage firearms: Caution should be exercised to avoid exposure of camouflage patterns to strong solvents or insect repellants.

RE-ASSEMBLY



Wear eye protection during assembly to protect your eyes from oil spatter or spring loaded components.

MAGPUL® SGA® STOCK INSTALLATION



Before removing or installing an accessory on your firearm, set the safety button fully rearward to the "ON" (SAFE) position and keep the muzzle pointed in a safe direction. Open the action, visually and physically check the chamber, elevator, and magazine tube to ensure the firearm is completely unloaded (Refer to the Unloading The Firearm section of this owner's manual).

1. Align receiver plate on stock. Then align stock on receiver with the plate in between.
2. Install receiver bolt and tighten using a 1/4" allen key.
3. Install thumb strip onto stock by sliding tab into the thumb strip groove, then snap into place.

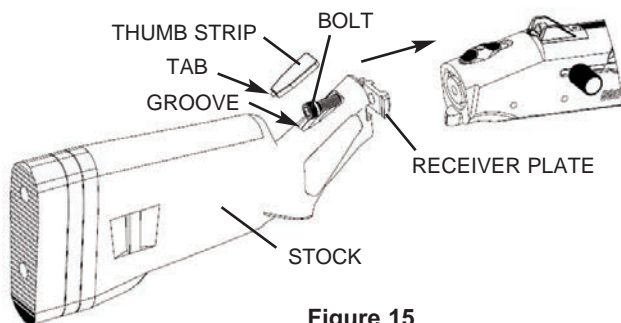

Figure 15

ACTION RE-ASSEMBLY



Ensure there is no presence of ammunition while assembling your firearm. Be sure the chamber and magazine tube remain unloaded.

1. Ensure the safety button is fully rearward in the "ON" (SAFE) position. Place the bolt assembly on top of the slide, making sure it sits flat.
2. Install the bolt and slide assemblies into the front of the receiver through the opening for the barrel. The slide assembly may need to be "wiggled" side to side in order to engage the tracks in the receiver. The bolt assembly will stop when it is nearly flush with the front of the receiver. Press the bolt release, this will allow the action to seat in the receiver. Push the bolt assembly rearward into the receiver just far enough for the operating handle slot to become fully visible (Figure 16).
3. To install the operating handle, hold the operating handle with the notch facing rearward and push the handle through the bolt assembly into the slide assembly. Push the operating handle inward until the internal plunger in the slide assembly engages with the notch in the operating handle. Gently tug outward on the operating handle to ensure it is securely engaged in the bolt assembly. The operating handle will now prevent the action from coming out of the receiver.

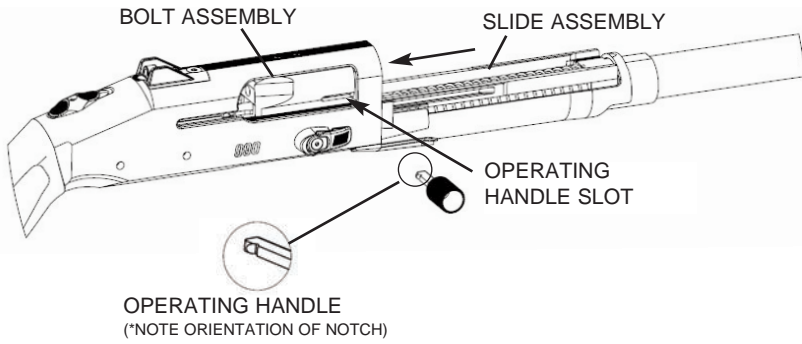

Figure 16

TRIGGER HOUSING ASSEMBLY RE-ASSEMBLY

1. Insert the trigger housing assembly into the receiver and align the two trigger housing retaining pin holes (Figure 17).
2. Push in the trigger housing retaining pins until they are flush with the sides of the receiver.

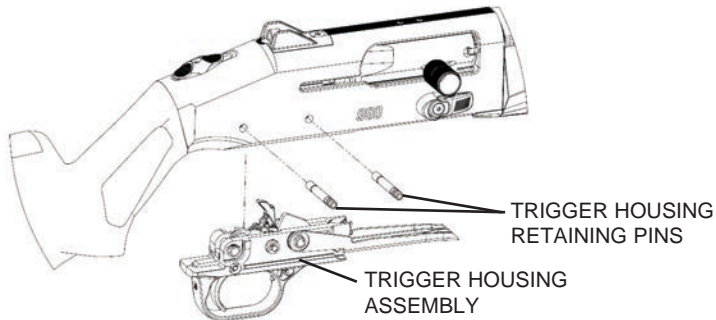

Figure 17

GAS PISTON RE-ASSEMBLY

1. Slide the outer two piston rings onto the piston. Orient the slots 180 degrees apart as shown in Figure 18A.
2. Push the retaining ring over the piston into the retaining ring groove. Start with one end of the ring engaged in the groove and work around clockwise or counter clockwise (Figure 18B).

NOTE: Ensure both the outer rings and inner ring can rotate freely. Failure to do so will cause improper functioning of your firearm.

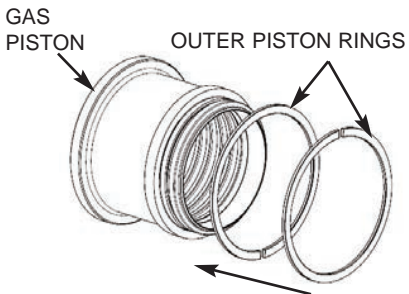

Figure 18A

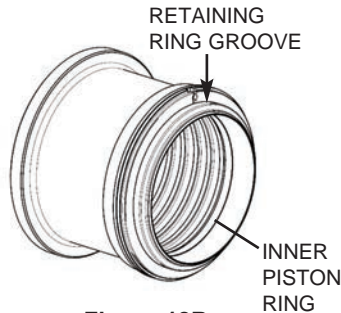

Figure 18B

BARREL AND GAS SYSTEM COMPONENT RE-ASSEMBLY



When reinstalling the barrel onto the firearm, **YOU MUST** ensure that the gas piston is present in the gas cylinder portion of the barrel prior to installing the barrel. Failure to do so may result in a dangerous malfunction, damage to the firearm and could cause death, serious injury, or property damage to you or those around you when the firearm is fired. The firearm's owner must accept full responsibility for the correct reassembly and functioning of the firearm after any disassembly or replacement of parts.

The action must be in the open position (bolt fully rearward). (See "Opening The Action" section.)

1. Reinsert the gas piston assembly into the gas cylinder portion of the barrel (Figure 19).
2. Install the barrel into the receiver, the gas cylinder slides over the magazine tube. Continue to push the barrel into the receiver until fully seated.
3. Slide the forearm assembly onto the magazine tube. When past the front sight and halfway onto the magazine tube, squeeze the rear of the forearm together slightly and slide the handguard band back onto the forearm assembly. **Ensure it is installed correctly as shown in Figure 19 or forearm assembly may bind.** Slide the forearm assembly fully rearward onto the magazine tube until seated against the piston stop.
4. Hand-tighten the magazine tube sleeve to secure the forearm assembly (Figure 19). **Do not over-tighten or you may damage the magazine tube.**
5. Install the barrel clamp by attaching the two halves. Note orientation of M-Lok[®] slot (Figure 19). Use a 5/32" allen key to tighten down the screws provided (one on each side). **Do not over-tighten or you may damage the magazine tube, barrel, and/or barrel clamp.**

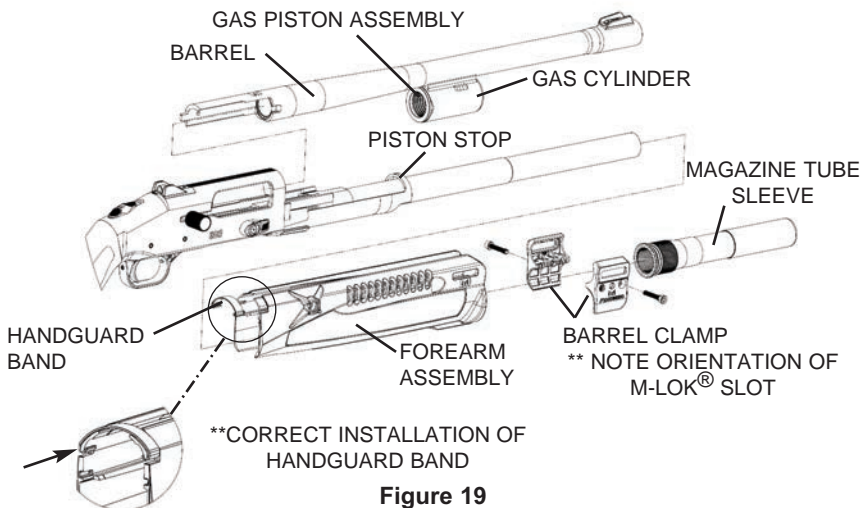

Figure 19



Be certain to check your firearm for proper functioning before firing any live ammunition (refer to the Function Testing section of this Owner's Manual).

FUNCTION TESTING



AFTER PERFORMING ANY WORK ON YOUR FIREARM SUCH AS CLEANING, DISASSEMBLY, OR INSTALLATION OF ANY ACCESSORY, CHECK YOUR FIREARM FOR PROPER FUNCTIONING BEFORE USING AND/OR FIRING ANY LIVE AMMUNITION.



Set the safety button fully rearward to the “ON” (SAFE) position and keep the muzzle pointed in a safe direction. Lock the action open, visually and physically check the chamber, elevator, and magazine tube to ensure the firearm is completely unloaded (Refer to the Unloading The Firearm section of this owner’s manual).



KEEP THE MUZZLE POINTED IN A SAFE DIRECTION AT ALL TIMES THROUGHOUT THE FOLLOWING STEPS! FAILURE TO DO SO COULD CAUSE DEATH, SERIOUS INJURY, OR PROPERTY DAMAGE TO YOU OR THOSE AROUND YOU IF THE FIREARM HAS NOT BEEN PROPERLY UNLOADED AND FIRES WHILE YOU ARE TESTING ITS FUNCTION!

1. Move the safety button fully rearward to the “ON” (SAFE) position (Figure 1).
2. Hold the firearm in your left hand by the forearm assembly. Grasp the operating handle and pull the bolt fully rearward. It should lock in the open position.
3. With fingers and other objects clear of the ejection port, press the bolt release and allow the bolt to move forward under spring pressure. It should lock in the fully closed position. Repeat this procedure several times to check for free movement of the action assembly.
4. With the action closed and the safety button fully rearward in the “ON” (SAFE) position, pull the trigger fully rearward. The hammer should not fall (NO FIRE).
5. Remove your finger from the trigger. Move the safety button forward to the “OFF” (FIRE) position. The hammer should not fall (NO FIRE).
6. Leave the safety button forward in the “OFF” (FIRE) position.
7. Pull the trigger rearward. The hammer should fall (FIRE).
8. Open the action. Move the safety button rearward to the “ON” (SAFE) position.



IF YOUR FIREARM DOES NOT PERFORM AS DESCRIBED IN ANY OF THE ABOVE STEPS, CONTACT THE PRODUCT SERVICE CENTER IMMEDIATELY. DO NOT ATTEMPT TO LOAD OR USE THE FIREARM.



Firearms are complex mechanisms. Any modification, alteration, or improper fitting of parts may result in a dangerous malfunction, damage to the firearm, and could cause death, serious injury or property damage to you or those around you. The firearm’s owner must accept full responsibility for the correct reassembly and functioning of the firearm after any disassembly or replacement of parts.

SIGHTS



Before performing any sight adjustments on your firearm, set the safety button fully rearward to the "ON" (SAFE) position and keep the muzzle pointed in a safe direction. Lock the action open, visually and physically check the chamber, elevator and magazine tube to ensure the firearm is completely unloaded (Refer to the Unloading The Firearm section of this owner's manual).

The front sight varies depending on the model. If your model comes equipped with a fiber optic front sight, to change or install different colored lightpipes, see instructions included with the front sight accessory kit included with your firearm.

Some Mossberg shotguns may be fitted with a receiver machined to allow the direct mounting of micro red dot (reflex) sighting systems.

REFLEX SIGHT MOUNTING

Using a 3/32" allen key, remove the two screws retaining the optic cover plate (Figure 20A). Be sure to keep the screws and the optic cover for future re-installation.

Following the optic manufacturer's installation instructions, test fit the reflex sight in the machined area (Figure 20B) on the receiver. Make sure the reflex sight is resting flat on the receiver and positioned over the mounting holes.

Using two M3x0.5mm screws provided by the optic manufacturer or the two M3x0.5mm button head screws included in the accessory package, fasten the optic to the receiver. Check to ensure that the screws are of the proper length and do not protrude into the inside of the receiver prior to securing the optic. The screws may need to be shortened by filing or grinding in order to get a proper fit.

Check screw tightness on a regular basis and re-tighten to proper specifications as necessary. If an optical sight is not mounted on the slide, reinstall the optics cover plate using a 3/32" allen key and tighten the original screws to 12 in/lbs. Over-tightening may cause damage. Thread locker is optional. Medium blue strength Loctite® is recommended. Apply a small amount to the screw threads only before assembling to ensure stability.



Be certain to check your firearm for proper functioning before firing any live ammunition (refer to the Function Testing section of this Owner's Manual).

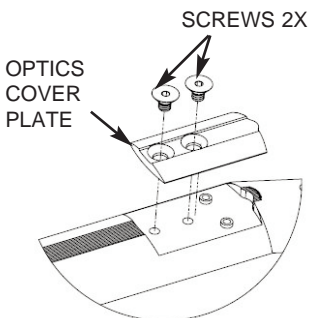

Figure 20A

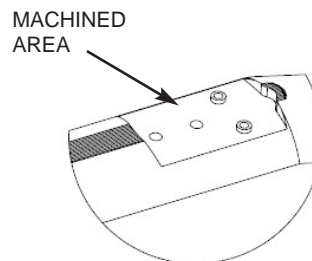

Figure 20B

STOCK SPACER SYSTEM



Before performing any stock adjustments on your firearm, set the safety button fully rearward to the "ON" (SAFE) position and keep the muzzle pointed in a safe direction. Lock the action open, visually and physically check the chamber, elevator and magazine tube to ensure the firearm is completely unloaded (Refer to the Unloading The Firearm section of this owner's manual).



Wear eye protection during disassembly and assembly to protect your eyes from oil spatter or spring loaded components.

Your 990™ model is equipped with a Magpul® SGA® stock that allows for length of pull (LOP) adjustment. This is achieved by using the additional spacers included with this firearm.

The length of pull on the Magpul® SGA® stock is adjustable in 1/2" increments. Adjustment range is 12-14 inches.

To adjust your length of pull:

1. Remove the buttpad slider by first removing the screw using a 1/8" allen key or slotted screwdriver (Figure 21A). Slide the buttpad slider out of the stock.
2. Add 1/2" LOP spacers onto the buttpad slider. Spacers nest into each other with the open end toward the buttpad (Figure 21B). Up to 4 spacers can be installed to achieve desired LOP.



Do not use the buttpad slider extended without LOP spacers between slider and stock. This will cause damage to the stock.

3. Reinstall the buttpad slider by sliding it back into stock until it stops. Reinstall the screw and tighten. **Do not overtighten you may cause damage to the stock or slider.**



After performing any work on your firearm such as cleaning, disassembly, or installation of any accessory, check your firearm for proper functioning before firing any live ammunition.



Figure 21A

Figure 21B

For further information on your Magpul® stock visit:
<https://magpul.com/firearm-accessories/stocks/shotgun.html>

CHOKE TUBES



Before removing or installing any choke tube, set the safety button fully rearward to the "ON" (SAFE) position and keep the muzzle pointed in a safe direction. Lock the action open, visually and physically check the chamber, elevator, and magazine tube to ensure the firearm is completely unloaded (Refer to the Unloading The Firearm section of this owner's manual).



Do not use bent or deformed choke tubes as these may result in tube or barrel damage upon firing which could cause serious personal injury to you or those around you. Inspect choke tubes periodically to insure they are properly installed and in good condition. Pay special attention to the threaded end of the choke tube to be certain it is not deformed or dented.



Never fire this firearm without a choke tube properly installed. Failure to do so will damage the precision threads on the inside of the barrel. Firing this firearm with loose choke tubes may lead to damage to the choke tube and barrel, as well as serious personal injury to you or those around you.

CARE & CLEANING: The precision threads on your choke tube should be kept clean and lightly oiled at all times.

NOTE: During cleaning of the barrel, be certain a choke tube is properly installed. This will avoid residue build-up on threads.

Choke tubes provided with your firearm vary per model. The 990™ comes with a flush mounted Accu-Choke™ installed.

These choke tubes are designed for use with Lead, Steel, and other non-toxic shot. Each durable tube is clearly marked, as a guide, with the pattern it will produce.

TO REMOVE THE CHOKE TUBE:

For flush mounted Accu-Choke™ tubes use the wrench provided, turning it counterclockwise. Place the choke tube on a clean, dry surface.

TO INSTALL THE CHOKE TUBE:





For flush mounted Accu-Choke™ tubes use the wrench provided, turning it clockwise until snug. Do not use excessive force when installing.



Choke tube tightness should be checked periodically to avoid damage to the choke, firearm, and to prevent injury to you or those around you.

* Lead, steel, and other non-toxic shot patterns will vary substantially depending on shell length, shot size, brand of ammunition, and the individual barrel. The shooter is urged to conduct pattern tests before field use.

STORAGE

-  Always store this firearm securely and unloaded. Failure to do so could result in an unintentional discharge.
-  Use the locking device supplied with the firearm for storage. The use of a locking device or cable lock is only one aspect of responsible firearms storage (see Cable Lock section of this owner's manual).
-  While locking devices are an important aid to security measures, they are not a substitute for safe firearm handling and proper storage. Mechanical and locking devices can fail and/or be bypassed with enough time, knowledge, determination and equipment.
-  Keep out of reach of children. Firearms should be stored unloaded in a location that is secure and inaccessible to children and any other unauthorized person, with ammunition locked securely in a different location.
-  Never act in an irresponsible manner or ignore any established rules of safety when using or storing firearms.

After unloading, cleaning and lubrication and function testing this firearm as instructed in this owner's manual, follow these instructions on storage to properly and securely store your firearm:

1. Select a safe and secure location for storage, one that conforms to the instructions and recommendations of this manual and all applicable laws, including but not limited to use of the cable lock provided with this firearm (see Cable Lock section of this owner's manual).
2. If possible, do not store the firearm in the factory-supplied case as moisture may collect and cause damage.
3. If you plan on storing the firearm for extended periods of time between uses, clean and lubricate the firearm per instructions in this manual every six months (see Cleaning and Lubrication section of this owner's manual).

CABLE LOCK



Before installing the cable lock, move the safety button fully rearward to the "ON" (SAFE) position. Visually and physically inspect the chamber, elevator, and magazine tube to be certain the firearm is completely unloaded. Keep the muzzle pointed in a safe direction while opening the action.



Do not close the action with the cable lock installed. This may result in damage to your cable lock and firearm.



Store your cable lock keys in a separate location.

To install the cable lock:

1. Ensure the action remains locked in the open position to install your cable lock.
2. Unlock the cable lock with the key provided, leave the key in the lock body.
3. Pass the free end of the cable through the ejection port and down through in front of the elevator in the loading port.
4. Align the free end of the cable with the open hole on the lock body. Press and hold firmly in place.
5. Turn the key counter clockwise until locked. Remove the key.
6. Tug on lock body to be sure the cable lock is secure. If not locked, reinsert the key and repeat steps 4 and 5.
7. To unlock the cable lock, insert the key into the lock body. Turn clockwise and pull on the lock body until the cable releases.

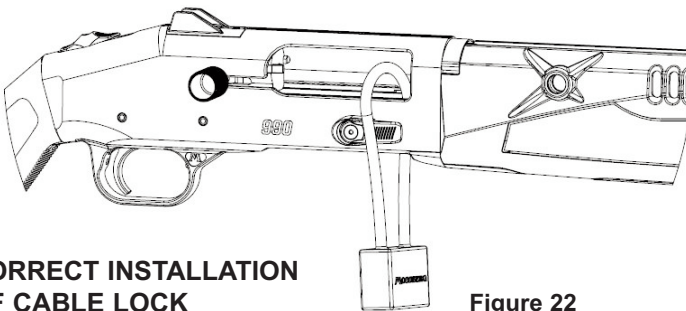

**CORRECT INSTALLATION
OF CABLE LOCK**

Figure 22



Ensure the cable lock is installed correctly as shown in Figure 22. Improper installation of the cable lock or storage of your firearm could cause, death, serious injury or property damage to you or those around you.

SERVICE INSTRUCTIONS

Should your firearm or any component of your firearm require service, ship your entire firearm (please do not send components only), via your chosen carrier, postage paid (we do not accept C.O.D. shipments), following these instructions:

Repairs in the U.S.

For faster repair service, please start the process by filling out our Service Request Form online at <http://www.mossberg.com/service> prior to shipping your firearm.



- **Make absolutely certain your firearm is unloaded.**
- **Do not send ammunition with your firearm.**
- Remove all accessories from your firearm such as scopes, slings, scope mounts, etc.
- Ship your firearm in a suitable container, packaging it securely to prevent parts from shifting and/or damage during shipping.
- Include a note with a clear description of the service you wish us to perform, your complete return shipping address (no P.O. boxes please), your daytime telephone number and your e-mail address (if available).
- It is advisable to place your correspondence inside your shipping container when shipping.

SHIPPING ADDRESS

MPSC
1001 Industrial Blvd.
Eagle Pass, TX 78852

If you have any service related questions, please contact the Product Service Center at (800) 363-3555 or service@mossberg.com

TO ORDER PARTS

To order parts from the Product Service Center, you can fax, phone, email, or mail your order to one of the below numbers/addresses.

Fax Number: (203) 230-5420
Phone Number: (800) 363-3555
E-mail Address: service@mossberg.com
Mailing Address: MPSC
1001 Industrial Blvd.
Eagle Pass, TX 78852
Attn: Order Department

Please provide your name, address, city, state, zip, your daytime phone number and e-mail (if available). The Product Service Center will need the Model Number, Serial Number, Gauge/Caliber, Finish, Item Number, and Part Name. There is a \$7.50 (U.S.) minimum parts order charge. Most major credit cards, money orders, and bank drafts are accepted.

Service outside of the U.S.A.

For Mossberg firearm parts and service requirements outside of the United States, customers are requested to contact the closest Mossberg stocking dealer/distributor.

MOSSBERG WARRANTY
990™ AUTO-LOADING SHOTGUN
TWO (2) YEAR LIMITED WARRANTY

Limited Warranty: O.F. Mossberg & Sons, Inc. ("Mossberg") warrants to you, the original retail purchaser of a new Mossberg® 990™ Auto-Loading Shotgun (the "Mossberg firearm"), that the Mossberg firearm will be free of defects in material or manufacture for a period of two (2) years from the date of your purchase of the new Mossberg firearm (the "Warranty Period") in the United States or Canada. This is the only express warranty on the Mossberg firearm.

MOSSBERG MAKES NO OTHER WARRANTIES OF ANY KIND OR CONDITIONS, INCLUDING, BUT NOT LIMITED TO ANY IMPLIED WARRANTY OF MERCHANTABILITY OR FITNESS FOR A PARTICULAR PURPOSE.

The implied warranties of merchantability and fitness for a particular purpose, and all other warranties not expressly made herein are expressly disclaimed. All disclaimers and limitations of liability shall still apply even if the limited remedy of repair or replacement fails of its essential purpose. There are no warranties which extend beyond the description on the face hereof. Any action against Mossberg and/or any Mossberg affiliates based on an alleged breach of this limited warranty must be brought within one (1) year of the claimed breach.

This Limited Warranty gives you specific legal rights, and you may have other rights that vary from State to State.

Purchaser's Remedy: During the Warranty Period, Mossberg will, at its sole option and discretion, (1) repair the Mossberg firearm or any part thereof that, upon examination and testing by Mossberg, does not conform to the Limited Warranty without charge to you for parts or labor, or (2) replace the Mossberg firearm with a new or similar model. THIS REMEDY SHALL BE YOUR EXCLUSIVE AND SOLE REMEDY FOR ANY BREACH OF WARRANTY. MOSSBERG SHALL NOT BE RESPONSIBLE FOR ANY OTHER EXPENSES, LOSSES OR INCONVENIENCE THAT YOU MAY SUSTAIN AS A RESULT OF THE PURCHASE, USE, MALFUNCTION OR DEFECTIVE CONDITION OF THE MOSSBERG FIREARM. Mossberg reserves the right to inspect, examine and/or test the Mossberg firearm to assess any claim made under the Limited Warranty.

EXCLUSIONS: THIS WARRANTY DOES NOT COVER THE SURFACE FINISH OF ANY MATERIAL, THE COSMETIC APPEARANCE OF THE MOSSBERG FIREARM OR ANY DAMAGE CAUSED BY:

- (1) NORMAL WEAR AND TEAR;
- (2) FAILURE TO PERFORM PROPER CARE AND MAINTENANCE;
- (3) ACCIDENTS, ABUSE OR NEGLIGENCE;
- (4) BARREL OR BORE OBSTRUCTIONS;
- (5) FAILURE TO FOLLOW THE INSTRUCTIONS AND WARNINGS THAT ACCOMPANY THE MOSSBERG FIREARM; OR
- (6) THE USE OF DEFECTIVE, NON-SAAMI STANDARD, REMANUFACTURED, HAND-LOADED, AND/OR RELOADED AMMUNITION;
- (7) THE USE OF INCORRECT AMMUNITION, EX. WRONG GAUGE;
- (8) DISASSEMBLY BEYOND THE INSTRUCTIONS OF THIS MANUAL;
- (9) CRIMINAL, NEGLIGENT OR IMPROPER USE;
- (10) OTHER FACTORS BEYOND MOSSBERG'S CONTROL.

IN ADDITION, ANY UNAUTHORIZED REPAIRS, ALTERATIONS OR MODIFICATIONS TO THE MOSSBERG FIREARM WILL AUTOMATICALLY VOID THE LIMITED WARRANTY.

(CONTINUED ON NEXT PAGE)

LIMITATION OF DAMAGES: EXCEPT WHERE PROHIBITED BY LAW, MOSSBERG AND AFFILIATES, OFFICERS, DIRECTORS, SHAREHOLDERS, EMPLOYEES, OR AGENTS WILL NOT BE LIABLE FOR ANY LOSS OR DAMAGE WHATSOEVER ARISING FROM THE USE OF THIS MOSSBERG FIREARM, WHETHER DIRECT, INDIRECT, SPECIAL, INCIDENTAL, CONSEQUENTIAL OR PUNITIVE, REGARDLESS OF THE LEGAL THEORY ASSERTED, INCLUDING CONTRACT, WARRANTY, NEGLIGENCE, OR STRICT LIABILITY. SOME JURISDICTIONS DO NOT ALLOW LIMITATIONS ON HOW LONG AN IMPLIED WARRANTY LASTS, OR THE EXCLUSION OF INCIDENTAL OR CONSEQUENTIAL DAMAGES, SO THE ABOVE LIMITATIONS MAY NOT APPLY TO YOU.

Warranty Service: To obtain service under this Limited Warranty, you must follow the instructions found in the "Service Instructions" section of the Owner's Manual and return the Mossberg firearm to the authorized Product Service Center. You are responsible for all shipping costs to the Product Service Center. Mossberg will not accept COD shipments of any Mossberg firearm for service. After repair or replacement under warranty, the Mossberg firearm or a similar model will be returned to you, return postage paid by Mossberg. If we replace the Mossberg firearm, we will keep the firearm that you returned to Mossberg, and you hereby relinquish any and all rights in such returned firearm.

Modification of Warranty: No agent, representative, distributor, or authorized dealer of Mossberg firearms has any authority to modify the terms or conditions of the Limited Warranty in any way. The Limited Warranty may only be modified in writing by an authorized officer of Mossberg.

THIS LIMITED WARRANTY IS EFFECTIVE OCTOBER 1, 2025.

MOSSBERG 990™ AUTOLOADING SHOTGUN EXPLODED VIEW PARTS LIST

| ITEM | DESCRIPTION | ITEM | DESCRIPTION |
|-------|--------------------------|------|--------------------------------|
| 1 | MAGAZINE TUBE, SLEEVE | 19 | FLAT SCREW, ACTION RELEASE |
| 2 | BARREL CLAMP | 20 | BUTTON, ACTION RELEASE |
| 3 | BARREL CLAMP SCREWS | 21 | COVER, BUTTON ACTION RELEASE |
| 4 | FORARM ASSEMBLY | 22 | SHELL STOP, REAR |
| 5 | BAND, HANDGUARD | 23 | FRONT SHELL STOP SPRING |
| 6 | FOLLOWER | 24 | FRONT SHELL STOP |
| 7 | MAGAZINE SPRING | 25 | FRONT SHELL STOP PIN |
| 8 | MAGAZINE SPRING RETAINER | 26 | SHELL STOP PIVOT PIN |
| 9 | ACTION RETURN SPRING | 27 | PIVOT PIN CLIP |
| 10 | PISTON STOP | 28 | SPRING, REAR SHELL STOP |
| **11 | SLIDE ASSEMBLY | 29 | TRIGGER HOUSING RETAINING PIN |
| 12 | BOLT HANDLE | 30 | RECEIVER PLATE |
| **13 | BOLT ASSEMBLY | 31 | STOCK |
| 14 | BARREL | 32 | STOCK BOLT |
| 15 | GAS PISTON | 33 | THUMB STRIP |
| 16A | RETAINER, PISTON RING | 34 | REAR SIGHT |
| 16B | OUTER PISTON RING | 35 | MOUNTING SCREW, OR COVER PLATE |
| **16C | PRESSURE RING SEAL | 36 | FRONT DUMMY SCREW |
| 17 | MAGAZINE TUBE, EXTENDED | **37 | TRIGGER HOUSING ASSEMBLY |
| **18 | RECEIVER ASSEMBLY | 38 | ACCU-CHOKE™ CHOKE TUBE |

*** ITEMS ON PARTS LIST ARE RESERVED FOR QUALIFIED GUNSMITHS OR THE AUTHORIZED PRODUCT SERVICE CENTER ONLY.

MOSSBERG 990™ AUTOLOADING SHOTGUN EXPLODED VIEW

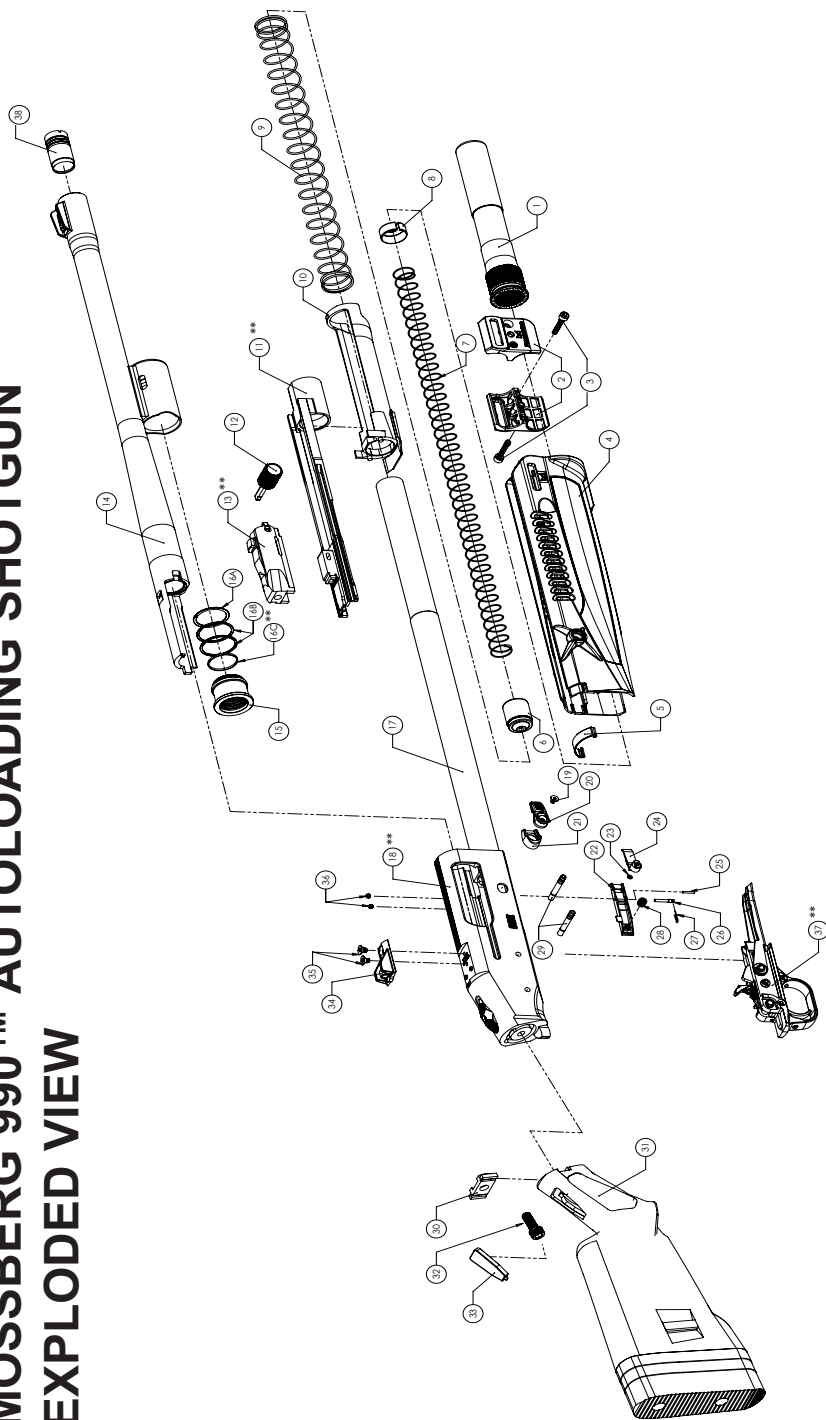



NOTES



FIREARMS SAFETY DEPENDS ON YOU. MAKE NO MISTAKE ABOUT IT!

From the time an individual picks up a firearm, that individual shooter becomes a part of a system over which he or she has complete control. He or she is the only part of the system that can make a gun safe – or unsafe. Hunting and target shooting are among the safest of all sports. This booklet is intended to make them even safer – by re-emphasizing and reaffirming the basics of safe gun handling and storage and by reminding each individual shooter that he or she is the key to firearms safety. You can help meet this responsibility by enrolling in hunter safety or shooting safety courses. You must constantly stress safety when handling firearms, especially to children and non-shooters. Newcomers in particular must be closely supervised when handling firearms with which they may not be acquainted. Don't be timid when it comes to gun safety. If you observe anyone violating any safety precautions, you have an obligation to suggest safer handling practices, such as those in this booklet. Please read these rules carefully and follow the safety procedures outlined. Firearms safety is up to you. Make no mistake about it.

- 1. ALWAYS KEEP THE MUZZLE POINTED IN A SAFE DIRECTION**
- 2. FIREARMS SHOULD BE UNLOADED WHEN NOT ACTUALLY IN USE**
- 3. DON'T RELY ON YOUR GUN'S "SAFETY"**
- 4. BE SURE OF YOUR TARGET AND WHAT'S BEYOND IT**
- 5. USE CORRECT AMMUNITION**
- 6. IF YOUR GUN FAILS TO FIRE WHEN THE TRIGGER IS PULLED, HANDLE WITH CARE**
- 7. ALWAYS WEAR EYE AND HEARING PROTECTION WHEN SHOOTING**
- 8. BE SURE THE BARREL IS CLEAR OF OBSTRUCTIONS BEFORE SHOOTING**
- 9. DO NOT ALTER OR MODIFY YOUR GUN, AND HAVE GUNS SERVICED REGULARLY**
- 10. LEARN THE MECHANICAL AND HANDLING CHARACTERISTICS OF THE FIREARM YOU ARE USING**

*Courtesy of
Sporting Arms and Ammunition Manufacturers' Institute, Inc.*