

**MOSSBERG™
INTERNATIONAL**

**OWNERS
MANUAL**

MAVERICK® SA™

12GA AUTOLOADING SHOTGUN

IMPORTANT: “SAFETY WARNINGS” — NOTE THE SYMBOL 

THESE SAFETY WARNINGS ARE FOR YOUR PROTECTION AS WELL AS THE SAFETY OF OTHERS. DISREGARDING INFORMATION IN THIS MANUAL COULD CAUSE DEATH, SERIOUS INJURY OR PROPERTY DAMAGE TO YOU OR THOSE AROUND YOU.



Do not attempt to load, handle or use your firearm until you read and understand the information contained in this owner's manual. Understand and follow all instructions and warnings in their entirety. Before handling your firearm, you should learn how it operates and how to maintain it. This includes knowing its basic parts, how the manual safety and other safety features operate, how to safely open and close the action, and how to safely load and unload ammunition from the firearm. Improper use and handling is dangerous and could cause death, serious injury or property damage to you or those around you. All users of the firearm must become thoroughly familiar with the instructions in this manual.



This manual is not a comprehensive guide to firearm safety. Mossberg recommends that new firearm owners and/ or shooters seek professional training from qualified instructors prior to handling any firearm.



Be certain this owner's manual is available for reference and is kept with this firearm if transferred to another party. If this manual is lost or misplaced, contact the Product Service Center for a free replacement copy or visit www.mossberg.com.



After performing any work on your firearm such as cleaning, adjustments, disassembly or installation of any accessory, the firearm should be re-checked for proper functioning before using and/or firing live ammunition.



Firearms are complex mechanisms. Any modification, alteration, or improper fitting of parts may result in a dangerous malfunction, damage to the firearm, and could cause death, serious injury or property damage to you or those around you. The firearm's owner must accept full responsibility for the correct reassembly and functioning of the firearm after any disassembly or replacement of parts.



If you do not understand any of the material in this manual or have any questions, contact the Product Service Center or a qualified gunsmith.

MOSSBERG INTERNATIONAL, INC

P.O. BOX 497 • 7 GRASSO AVENUE, NORTH HAVEN, CONNECTICUT 06473
PHONE (800) 363-3555
www.mossberg.com

Safety and safe firearms handling is everyone's responsibility.



As the owner of a firearm, you must undertake the full-time responsibility of safe firearms handling for your own safety and the safety of those around you:

- Keep all firearms and ammunition out of the reach of children, or any unauthorized person.
- Store your firearms and ammunition separately, locked in a secure location.
- Be sure to read how to properly install your cable lock as instructed in this manual.
- Never store a loaded firearm.
- Never leave a loaded firearm unattended.
- Never transport a loaded firearm in a vehicle. When transporting your firearm, keep it unloaded, stored and secured within the confines of the vehicle.
- Unload your firearm when you have stopped shooting or when you have to climb a tree, fence or cross a slippery surface. Keeping your firearm unloaded when not in use will prevent an unintentional discharge should you accidentally slip, fall, drop or jar your firearm.
- The safety should remain in the “ON/SAFE” position and the firearm unloaded at all times until you are in a place where it is safe to shoot, keeping your finger off the trigger and outside the trigger guard until you are aiming at the intended target and have decided to fire.
- Never shoot at water, rocks, or any hard surfaces. Shots may glance off or ricochet off such surfaces and could cause death, serious injury or property damage to you or those around you.
- Be sure of your target and beyond. Make sure that your back stop is adequate to stop shots prior to firing.
- Do not use alcohol or drugs before or while handling firearms.
- Do not touch the trigger while the safety is being engaged or disengaged.



Remember, a firearm’s manual safety is a mechanical device which can never replace safe firearm handling practices.



Never rely on any mechanical mechanism or safety device to prevent the dangers of careless handling or pointing a firearm in an unsafe direction.



Always point the muzzle of your firearm in a safe direction, regardless of whether the firearm is loaded or unloaded. You should become thoroughly familiar with the function and operation of this firearm and the instructions supplied with it.



Always treat every firearm as if it is loaded. Give your firearm to someone with the magazine tube empty, the action open, and the safety in the “**ON/SAFE**” position, after you verify the firearm is unloaded. Insist on the same procedure when receiving a firearm from someone else. Learn the location of all the safety features of your firearm and how they operate.



Never place your finger inside the trigger guard or on the trigger unless you intend to fire. When you pull the trigger you must expect the firearm to fire and you must take full responsibility for your actions.





Always wear eye and hearing protection when firing a firearm. Firing a firearm without proper hearing protection can cause hearing loss. The use of eye protection during any type of shooting, disassembly, assembly and cleaning is important to protect your vision.





When using a firearm with mounted optics, maintain an adequate distance between the rear of the scope and your face at all times. Be certain the scope installation does not interfere with access to, or the proper functioning of the safety.

 **We specifically disclaim any responsibility for damage or injury whatsoever occurring in connection with, or as a result of, the use of faulty, or non-SAAMI standard, or “remanufactured”, or hand-loaded (reloaded) ammunition. Additionally, we disclaim any responsibility for damage or injury which results from any modifications or changes that are not a part of the firearm as delivered from the factory.**

 Check to be certain that the correct ammunition has been selected for use. Ensure it is the same gauge, length and type of shotshell as designated on the barrel. Failure to do so could cause death, serious injury or property damage to you or those around you.

 Always ensure that barrel and action are clear of obstructions before firing. Firing a blocked firearm could cause death, serious injury, or property damage to you or those around you.

 Never force a jammed action. This could cause a shotshell to explode resulting in death, serious injury or property damage to you or those around you.

 Should any shotshell fail to fire, keep the muzzle pointed in a safe direction for at least thirty (30) seconds in case the shotshell is a “hangfire” (delayed firing of the shotshell after being struck by the firing pin). Move the safety button to the “ON/SAFE” position. Pull the operating handle fully rearward, extracting and ejecting the misfired shotshell. Segregate the misfired shotshell from other ammunition. Do not attempt to refire a misfired shotshell. If the indent from the firing pin is light or absent, contact a qualified gunsmith or the Product Service Center.

 Do not drop, or allow anything to strike the firearm because, as with any firearm, an accidental discharge may result.

 Learn to clean your firearm thoroughly and make certain no oil, grease or other materials are blocking the barrel. Obstructions of any kind can cause death, serious injury or property damage.

 Practice proper firearm maintenance and safety. Make sure all exposed metal surfaces are coated with a thin film of oil, especially after being exposed to damp weather. (See the proper section of this manual for cleaning instructions.) Do not plug the barrel or store in a fabric-lined case, which will absorb lubricants from the firearm. Always store this firearm with the chamber empty and magazine tube unloaded. Failure to do so could result in an unintentional discharge.

 Before using the firearm after storage, follow complete instructions stated in this manual for re-familiarization with the firearm. A thorough inspection and function test should be performed before going into the field. Have your firearm periodically checked by a qualified gunsmith.

STATE-BY-STATE WARNINGS

Certain states require, by law, that their own specified warning notices, in larger-than-normal type be conspicuously included by the manufacturer, distributor, or retail dealer with firearms sold in that state. Mossberg International, Inc. ("Mossberg") sells its products in compliance with applicable laws and regulations. Because our products may be sold in these states, we include the following:



CALIFORNIA:

Firearms must be handled responsibly and securely stored to prevent access by children and other unauthorized users. California has strict laws pertaining to firearms, and you may be fined or imprisoned if you fail to comply with them. Visit the Web site of the California Attorney General at <https://oag.ca.gov/firearms> for information on firearm laws applicable to you and how you can comply. Prevent child access by always keeping guns locked away and unloaded when not in use. If you keep a loaded firearm where a child obtains and improperly uses it, you may be fined or sent to prison.



ADVERTENICA:

Las armas de fuego deben manipularse de manera responsable y segura para evitar el acceso de niños y otros usuarios no autorizados. California tiene leyes estrictas relacionadas con armas de fuego, y usted puede ser multado o encarcelado si no las cumple. Visite la pagina web del Procurador General de California en <https://oag.ca.gov/firearms> para obtener información sobre las leyes de armas de fuego que le son aplicables y cómo puede cumplirlas. Evite el acceso de niños manteniendo siempre las armas bloqueadas y descargadas cuando no estén en uso. Si mantiene un arma de fuego cargada donde un niño obtiene y la usa indebidamente, se le puede multar o enviar a prisión.



CONNECTICUT:

"UNLAWFUL STORAGE OF A LOADED FIREARM MAY RESULT IN IMPRISONMENT OR FINE."

**FLORIDA:**

“IT IS UNLAWFUL, AND PUNISHABLE BY IMPRISONMENT AND FINE, FOR ANY ADULT TO STORE OR LEAVE A FIREARM IN ANY PLACE WITHIN THE REACH OR EASY ACCESS OF A MINOR UNDER 18 YEARS OF AGE OR TO KNOWINGLY SELL OR OTHERWISE TRANSFER OWNERSHIP OR POSSESSION OF A FIREARM TO A MINOR OR A PERSON OF UNSOUND MIND.”

**MAINE:**

“ENDANGERING THE WELFARE OF A CHILD IS A CRIME. IF YOU LEAVE A FIREARM AND AMMUNITION WITHIN EASY ACCESS OF A CHILD, YOU MAY BE SUBJECT TO FINE, IMPRISONMENT OR BOTH. KEEP FIREARMS AND AMMUNITION SEPARATE. KEEP FIREARMS AND AMMUNITION LOCKED UP. USE TRIGGER LOCKS.”

**MARYLAND:**

“WARNING: Children can operate firearms which may cause death or serious injury. It is a crime to store or leave a loaded firearm in any location where an individual knew or should have known that an unsupervised minor would gain access to the firearm. Store your firearm responsibly!”

**MASSACHUSETTS:**

“WARNING FROM THE MASSACHUSETTS ATTORNEY GENERAL: This handgun is not equipped with a device that fully blocks use by unauthorized users.

More than 200,000 firearms like this one are stolen from their owners every year in the United States. In addition, there are more than a thousand suicides each year by younger children and teenagers who get access to firearms. Hundreds more die from accidental discharge. It is likely that many more children sustain serious wounds, or inflict such wounds accidentally on others. In order to limit the chance of such misuse, it is imperative that you keep this weapon locked in a

secure place and take other steps necessary to limit the possibility of theft or accident. Failure to take reasonable preventative steps may result in innocent lives being lost, and in some circumstances may result in your liability for these deaths.”

“IT IS UNLAWFUL TO STORE OR KEEP A FIREARM, RIFLE, SHOTGUN OR MACHINE GUN IN ANY PLACE UNLESS THAT WEAPON IS EQUIPPED WITH A TAMPER RESISTANT SAFETY DEVICE OR IS STORED OR KEPT IN A SECURELY LOCKED CONTAINER.”



NEW JERSEY:

“IT IS A CRIMINAL OFFENSE TO LEAVE A LOADED FIREARM WITHIN EASY ACCESS OF A MINOR.”



NEW YORK CITY:

“THE USE OF A LOCKING DEVICE OR SAFETY LOCK IS ONLY ONE ASPECT OF RESPONSIBLE WEAPON STORAGE. ALL WEAPONS SHOULD BE STORED UNLOADED AND LOCKED IN A LOCATION THAT IS BOTH SEPARATE FROM THEIR AMMUNITION AND INACCESSIBLE TO CHILDREN AND ANY OTHER UNAUTHORIZED PERSONS. NEW YORK CITY LAW PROHIBITS, WITH CERTAIN EXCEPTIONS, ANY PERSON FROM ACQUIRING MORE THAN ONE FIREARM, OR MORE THAN ONE RIFLE OR SHOTGUN, WITHIN A 90-DAY PERIOD.”



NORTH CAROLINA:

“IT IS UNLAWFUL TO STORE OR LEAVE A FIREARM THAT CAN BE DISCHARGED IN A MANNER THAT A REASONABLE PERSON SHOULD KNOW IS ACCESSIBLE TO A MINOR.”

Any person who resides in the same premises as a minor, owns or possesses a firearm, and stores or leaves the firearm (i) in a condition that the firearm can be discharged and (ii) in a manner that the person knew or should have known that an unsupervised minor would be able to gain access to the firearm, is guilty of a Class 1 misdemeanor if

a minor gains access to the firearm without the lawful permission of the minor's parents or a person having charge of the minor and the minor:

- (1) Possesses it in violation of G.S. 14-269.2(b);
- (2) Exhibits it in a public place in a careless, angry, or threatening manner;
- (3) Causes personal injury or death with it not in self defense; or
- (4) Uses it in the commission of a crime.



TEXAS:

“IT IS UNLAWFUL TO STORE, TRANSPORT, OR ABANDON AN UNSECURED FIREARM IN A PLACE WHERE CHILDREN ARE LIKELY TO BE AND CAN OBTAIN ACCESS TO THE FIREARM.”



WISCONSIN:

“IF YOU LEAVE A LOADED FIREARM WITHIN THE REACH OR EASY ACCESS OF A CHILD YOU MAY BE FINED OR IMPRISONED OR BOTH IF THE CHILD IMPROPERLY DISCHARGES, POSSESSES, OR EXHIBITS THE FIREARM.”

A note about the warnings and information contained in this manual:

The above warnings are not intended to be exhaustive. We strongly suggest that you check with your local licensed retailer or state police for additional information concerning firearms ownership, or hunting or target shooting rules that may be required by local law or regulation. Since such rules and regulations are subject to change, local authorities are in the best position to advise you on such matters.

TABLE OF CONTENTS

	Page
Nomenclature	9
Unpacking & Initial Assembly	10-11
Operating Instructions	12-20
The Mechanical Safety	12
Opening the Action	13
Closing the Action	14
Magazine Capacity	14
Loading the Firearm	14-15
Loading the Magazine Tube	16
Firing	17-18
To Clear a Malfunction/Jam	19
Unloading the Firearm	20
Disassembly & Maintenance	20-28
Disassembly	20-23
Cleaning and Lubrication	24-25
Re-Assembly	26-27
Function Testing	28
Accessories & Adjustments	29-33
Stock Spacer System	29-30
Extra Gas Piston & Gas Piston Selection	31
Choke Tubes	32-33
Drilled & Tapped Receiver for Picatinny Rail	33
Cable Lock	34
Storage	35
Service & Warranty	36-38
Exploded View & Parts List	39-40
Notes	41-43
The Basic Rules of Safe Firearms Handling	Back Cover





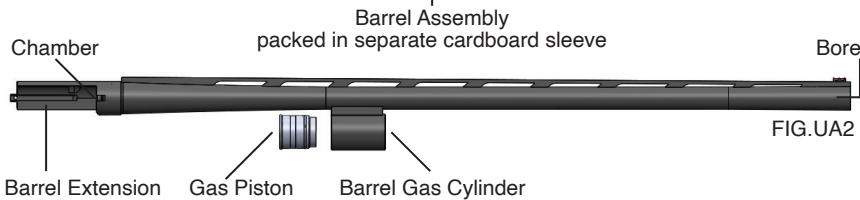

WARNING: This product can expose you to chemicals, including lead, which is known to the State of California to cause cancer and birth defects or other reproductive harm. For more information go to www.P65Warnings.ca.gov.

UNPACKING & INITIAL ASSEMBLY

Your firearm is packed and shipped from the factory in two sub-assemblies; The Action Assembly (together with the Stock, Receiver, Magazine Tube, Forearm and Magazine Cap) and the Barrel Assembly. The Barrel Assembly is packed in separate cardboard sleeve. Check FIG.UA1 for reference.



To install the Barrel in the Receiver, proceed as follows;

-  Be sure that the safety is in the “ON” (SAFE) position. Wear eye protection during cleaning and assembly to protect your eyes from oil splatter and spring loaded components.
-  Always be sure that the firearm is unloaded (refer to the Unloading section of this owner’s manual) by visually and physically checking the chamber, elevator and magazine tube.
-  Visually and physically inspect the chamber and bore of the barrel to make certain it is free of any obstructions, excessive oil or grease. If you are unable to remove any obstruction, bring the firearm to a qualified gunsmith or send it to a factory authorized Product Service Center. Obstructions of any kind could cause death, serious injury or property damage to you or those around you when the firearm is fired.
-  Do not attempt to remove a bore obstruction using a blank shotshell, or a shell from which the shot charge has been removed, or by shooting it out with another shotshell.
-  Never close the action or pull the trigger while the barrel is removed as damage could result to the firearm.

1- Unscrew the Magazine Cap by turning it counter-clockwise. When it's clear off the threads, remove it from the Magazine Tube by sliding it forward.

2- Slide the Forearm forward to remove it from the Magazine Tube.

3- Ensure the Gas Piston is correctly positioned in the Barrel Gas Cylinder. Check FIG.UA2 for reference.

4- Align the Barrel to the Receiver as shown in FIG.UA3 and slide the Barrel Gas Cylinder over the Magazine Tube.

5- When the Barrel Extension reaches the gap between the Receiver and the Bolt Assembly, push the Bolt Assembly forward (towards the Barrel Assembly) with your thumb while pulling the Barrel Assembly rearward (towards the Receiver) until the Barrel Extension is fully seated inside the Receiver. Check FIG.UA3 for reference.

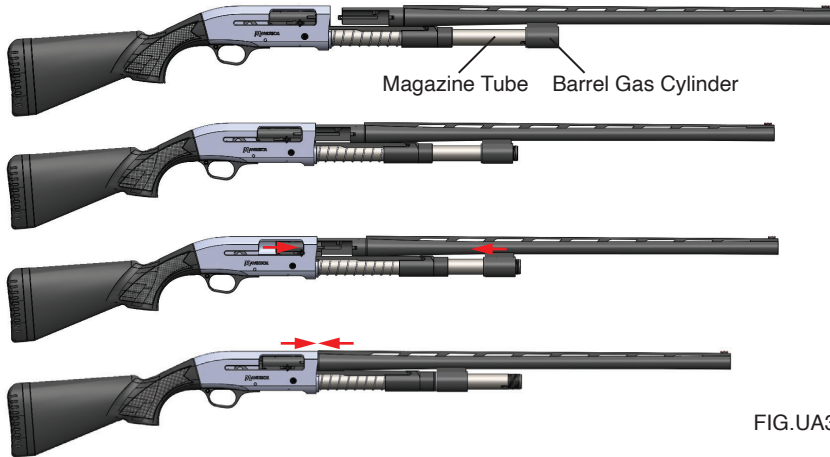

FIG.UA3

6- Slide the Forearm over the Magazine Tube until it sits flush against the Receiver. Check FIG.UA4 for reference.

7- Screw the Magazine Cap to the front of the Forearm, by placing it on the tip of Magazine Tube, then turning it clockwise. Screw it finger tight, do not over tighten !



FIG.UA4



Be certain to check your firearm for proper functioning before firing any live ammunition (refer to the Function Testing section of this Owner's Manual).

OPERATING INSTRUCTIONS



Read and understand this entire manual and its safety warnings before handling this firearm.

MECHANICAL SAFETY

The Safety Button is located at the top-rear of the trigger guard and must be manually moved to the desired position by the shooter.

To put the safety in “ON” (SAFE) position; button must be pushed from left side of the trigger guard, so it moves all the way to the right until it moves no further (protruding from the right side of trigger guard). See FIG.SB1.

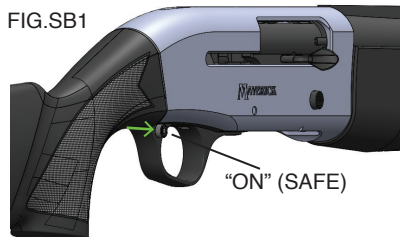

To put the safety in “OFF” (FIRE) position; button must be pushed from right side of the trigger guard, so it moves all the way to the left until it moves no further (protruding from the left side of trigger guard).

SAFETY BUTTON shows its RED STRIP when in “OFF/FIRE” position ! See FIG.SB2.

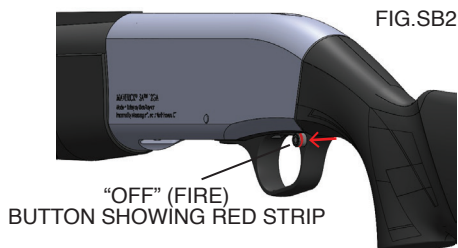

Remember, a firearm’s manual safety is a mechanical device which can never replace safe firearm handling practices.



Never rely on any mechanical mechanism or safety device to prevent the dangers of careless handling or pointing a firearm in an unsafe direction.



Keep your finger off the trigger and outside of the trigger guard until you are aiming at the intended target and have decided to fire. The safety should remain in “ON” (SAFE) position and the firearm unloaded at all times until you are in a place where it is safe to shoot.



Placing the safety in an intermediate position between the “ON” and “OFF” position can result in the user thinking the firearm is in a SAFE or FIRE position when it is not. Pulling the trigger with the safety in an intermediate position may cause the firearm to fire. Therefore, always move the safety fully to its intended position, “ON” or “OFF”, and then check to be sure it is where you want it to be. Never attempt to fire the firearm with the safety only partially engaged, as the firearm may discharge and could result in death, serious injury or property damage.

OPENING THE ACTION



Ensure the safety button is in the “ON” (SAFE) position. Visually and physically check the chamber, elevator, and magazine tube to be sure the firearm is unloaded. Keep the muzzle pointed in a safe direction at all times.

NOTE: The action is comprised of the Bolt Assembly, Operating Handle and the Action Arm Assembly (Action Arm and Action Arm Ring).

1. With the Safety Button in “ON” (SAFE) position, and the Muzzle pointed in a safe direction, hold the firearm in your left hand by the Forearm, and grasp the Operating Handle with your right hand.
2. Pull the Operating Handle fully rearward in one quick motion. When released, the Bolt will move slightly forward (towards the muzzle) and lock in the open position. Check FIG.OA1 for reference.
3. Remove the Chamber Plug from the Chamber. It is recommended that the Chamber Plug be reinstalled when the firearm is not in use as an added measure of safety to indicate the chamber is unloaded.

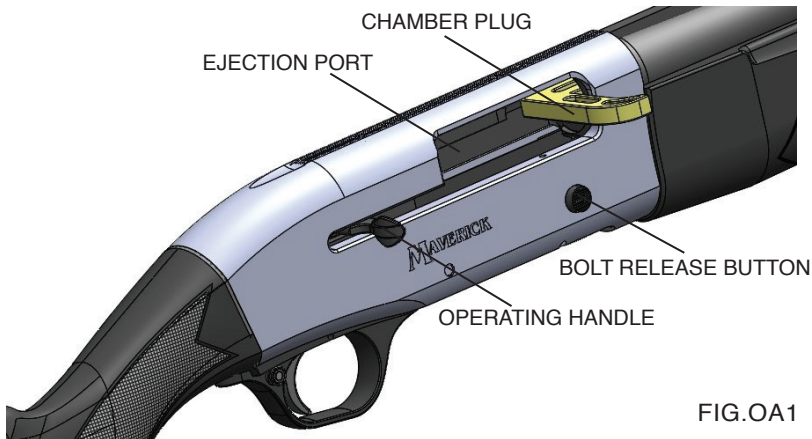

FIG.OA1



The bolt is always under spring pressure. When the bolt release is pushed with the bolt locked rearward, the bolt is driven forward toward the muzzle with considerable force. Do not have fingers or other objects in the ejection port or near the operating handle.



Visually and physically inspect the chamber and bore of the barrel to make certain it is free of any obstructions, excessive oil or grease. If you are unable to remove any obstruction, bring the firearm to a qualified gunsmith or send it to a factory authorized Product Service Center. Obstructions of any kind could cause death, serious injury or property damage to you or those around you when the firearm is fired.

CLOSING THE ACTION



Keep fingers clear of the operating handle and the ejection port when closing the action. FIG.OA1

With the safety button in the “ON” (SAFE) position, and the muzzle pointed in a safe direction, press the bolt release until the action releases. FIG.OA1

MAGAZINE CAPACITY

The MAVERICK SA™ Magazine Capacity is five (5) 2 ¾” shotshells. Depending upon shotshell variations, total capacity may be reduced by one shotshell. Magazine capacity may be decreased when using 3” shotshells.

Your shotgun may be equipped with an extended magazine tube for increased magazine capacity, it may also include a magazine plug to decrease magazine capacity (see “Installing The Magazine Plug” section).

You are responsible for complying with all laws regarding the limitations of magazine capacity.

INSTALLING THE MAGAZINE PLUG



Ensure the safety button is in the “ON” (SAFE) position. Visually and physically check the chamber, elevator, and magazine tube to be sure the firearm is unloaded. Keep the muzzle pointed in a safe direction at all times.

The Magazine Plug may be installed in the Magazine Tube or included inside the box. When installed, the Magazine Plug will reduce the Magazine Tube capacity to two (2) shells.

To remove or install the Magazine Plug; first unscrew and remove the Magazine Cap. Now you can remove or install the Magazine Plug from the tip-center of the Magazine Tube.

Replace the magazine cap finger tight only. Do not use pliers or a wrench to tighten the Magazine Cap.

LOADING THE FIREARM



WARNING: This product can expose you to chemicals, including lead, which is known to the State of California to cause cancer and birth defects or other reproductive harm. For more information go to www.P65Warnings.ca.gov.

The MAVERICK SA™ model is designed to fire 12 gauge (1 1/8 oz 1200 fps minimum) factory loaded shotshells and 3” factory loaded magnum shotshells.



Before loading, move the safety button to the “ON” (SAFE) position.



Before loading, visually and physically inspect the chamber and bore of the barrel for any obstruction, excessive oil or grease (the chamber is the rearmost part of the inside of the barrel). Obstructions of any kind could cause death, serious injury, or property damage to you or those around you.



During loading, never allow fingers or any other objects to contact the trigger. Keep the muzzle pointed in a safe direction at all times.



Do not load the firearm until ready for use! Unload the firearm when shooting has been completed! The safety button should always be in "ON" (SAFE) position whether or not the firearm is loaded.



Check to be certain that the correct ammunition has been selected for use. Ensure it is the same gauge, length and type of shotshell as designated on the barrel. Failure to do so could cause death, serious injury or property damage to you or those around you



Always inspect your ammunition before using it. Never use dirty, corroded or damaged ammunition. A shotshell failure could cause death, serious injury or property damage to you or those around you.



Use only new commercially manufactured ammunition which is in strict accordance with the standards of the Sporting Arms and Ammunition Manufacturers' Institute (SAAMI). If you are uncertain, contact your ammunition supplier for verification.

1. Open the Action by pulling the Operating Handle completely rearward until it locks in the open position. FIG.OA2
2. Load the first shotshell through the Ejection Port located on the right side of the Receiver. The shotshell can be inserted directly into the Chamber or placed on top of the Elevator. FIG.OA2



Because the bolt is under considerable spring pressure, Keep fingers clear of the operating handle and the ejection port when closing the action.

3. With the Safety Button in the "ON" (SAFE) position, and the Muzzle pointed in a safe direction, press the Bolt Release until the Action releases. FIG.OA2
4. The Action will close under spring force, chambering a live shotshell. **Be sure to keep fingers and other objects out of the ejection port !**



The firearm is now loaded and will fire if the safety is moved to the "OFF" (FIRE) position and the trigger is pulled! The safety button should be kept in the "ON" (SAFE) position until you are on target and have actually decided to fire. Keep the muzzle pointed in a safe direction at all times, and your fingers and any other objects away from the trigger area.

FIG.OA2



LOADING THE MAGAZINE TUBE



With the safety button in the “ON” (SAFE) position, and the bolt in the forward (closed) position, hold the firearm with the bottom of the receiver facing upward. **Keep the muzzle pointed in a safe direction at all times.**

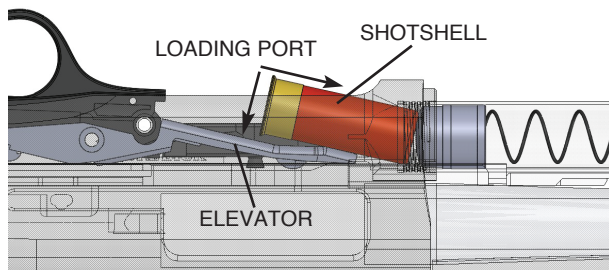

FIG.OA3

1. Carefully push the Shotshell into the Loading Port, depressing the Elevator FIG.OA3. This will expose the Magazine Tube opening within the Receiver.
2. Continue carefully pushing the Shotshell into the Magazine Tube until the Rim of the Shotshell is past the Shell Stop FIG.OA4. The Shell Stop will “snap” over the Rim of the Shotshell. Repeat this sequence to load each additional Shotshell.

If the Shotshell is not pushed all the way into the Magazine Tube, it will pop back out on the opposite side of the Elevator. If this should occur, while keeping the Muzzle pointed in a safe direction, simply open the Action by pulling the Operating Handle rearward, ejecting the Shotshell from the Chamber. Releasing the Operating Handle will allow the Action to close, automatically feeding the “misloaded” Shotshell into the Chamber.



The firearm is now loaded and will fire if the safety is moved to the “OFF” (FIRE) position and the trigger is pulled! The safety button should be kept in the “ON” (SAFE) position until you are on target and have actually decided to fire. Keep the muzzle pointed in a safe direction at all times, and your fingers and any other objects away from the trigger area.

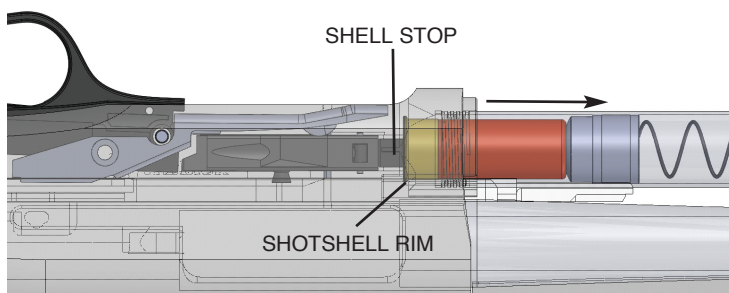

FIG.OA4

FIRING



Use of this product, including discharging firearms in poorly ventilated areas, cleaning firearms, or handling ammunition can result in exposure to chemicals, including lead, which are known to the state of California to cause serious physical injury, including cancer, birth defects or other reproductive harm. For more information, go to www.P65Warnings.ca.gov.



Have adequate ventilation at all times and wash hands thoroughly after exposure.



During firing, the operating handle travels rearward with considerable force and speed. Do not place hands or other objects in its path.



Always wear eye and hearing protection when firing a firearm. Firing a firearm without proper hearing protection can cause hearing loss. The use of eye protection during any type of shooting, disassembly, assembly and cleaning is important to protect your vision.



Be sure of your target and beyond. Make sure that your back stop is adequate to stop shots prior to firing.



When you pull the trigger you must expect the firearm to fire and you must take full responsibility for your actions.



Always ensure that barrel and action are clear of obstructions before firing. Firing a blocked firearm could cause death, serious injury, or property damage to you or those around you.



Do not attempt to remove a bore obstruction using a blank shotshell, or a shell from which the shot charge has been removed, or by shooting it out with another shotshell.

With the Muzzle pointed in a safe direction and the firearm held in the proper firing position, move the Safety Button to the "OFF" (FIRE) position.

Pulling the Trigger through its full travel to the rear will fire the firearm. Ensure the Muzzle is pointed in a safe direction before placing your finger on the Trigger.



After firing, the empty shotshell will be automatically ejected through the ejection port. Be sure all observers are clear of the path of ejection, as the empty shotshells are thrown out with considerable force and could cause injury.



This firearm automatically feeds the next live shotshell from the magazine tube into the chamber each time the firearm is fired, until all shotshells in the magazine tube are fired. You should be aware that no mechanical force on the part of the user is needed in this process and you should be alert to the fact that the chamber is loaded for you and the firearm is capable of firing again if the trigger is pulled.



This firearm is designed so that when all shotshells have been fired, the bolt will automatically lock rearward in the open position. You should never use this feature as a guide for determining if the firearm is empty! Always visually and physically inspect the chamber, elevator, and magazine tube for the presence of ammunition to ensure the firearm is completely unloaded.



Should any shotshell fail to fire, keep the muzzle pointed in a safe direction for at least thirty (30) seconds in case the shotshell is a “hangfire” (delayed firing of the shotshell after being struck by the firing pin). Move the safety button to the “ON” (SAFE) position. Pull the operating handle fully rearward, extracting and ejecting the misfired shotshell. Segregate the misfired shotshell from other ammunition. Do not attempt to refire a misfired shotshell. If the indent from the firing pin is light or absent, contact a qualified gunsmith or the Product Service Center.



If at any time during firing, the sound of any shotshell is noticeably louder or softer than previous shotshells fired, STOP! Do not load or fire additional shotshells. Move the safety button to the “ON” (SAFE) position. Keep the muzzle pointed in a safe direction and, while keeping the ejection port and loading port opening of the firearm turned away from your face (to protect your eyes in the event a defective shotshell explodes) Safely unload your firearm as instructed in the Unloading the Firearm section of this owner’s manual. Remove the barrel as instructed in the Disassembly section of this owner’s manual. Inspect the barrel and firearm for possible damage or obstructions to the chamber or bore. Firing the firearm with a bore obstruction can cause damage to the firearm and could cause death, serious injury, or property damage to you or those around you.



Some brands of ammunition may cause difficulty in extracting spent shotshell cases from the chamber. If this situation occurs, thoroughly clean the chamber with solvent (refer to Cleaning And Lubrication section of this owner’s manual). If this condition persists, we recommend you change to another brand of ammunition.



Use only new commercially manufactured ammunition which are in strict accordance with the standards of the Sporting Arms and Ammunition Manufacturers’ Institute (SAAMI). If you are uncertain, contact your ammunition supplier for verification.



All auto-loading firearms may occasionally experience a malfunction (jam) related to the feeding of ammunition. If a shotshell jams, do not attempt to force it into the chamber. Carefully remove it by following steps 1-5 in the To Clear A Malfunction (“Jam”) section of this owner’s manual. Most malfunctions are caused by improper ammunition, an improper grip on the firearm when firing, or improper lubrication. To help minimize the chance of malfunctions (jams), regularly perform cleaning/preventative maintenance on your firearm pursuant to the instructions in this manual. If you experienced a malfunction (jam) while using a new brand, type or lot of ammunition, try firing another type of ammunition to determine whether the ammunition was the source of the malfunction (jam).

TO CLEAR A MALFUNCTION / JAM

1. Set the Safety Button to the “ON” (SAFE) position, and ensure that the Muzzle pointed is in a safe direction.
2. Always keep the Muzzle pointed in a safe direction. Keep your finger off the Trigger and outside the Trigger Guard. Ensure the safety is in the “ON” (SAFE) position, and that you are wearing proper eye and hearing protection.
3. Unload the firearm until the Magazine Tube is empty.
(Refer to the Unloading the Firearm section of this owner’s manual).
4. Lock the Action in the open position (Refer to Opening the Action section of this owner’s manual).
5. Visually and physically inspect the Chamber, Elevator and Magazine Tube to be certain the firearm is unloaded, and that the Shotshell that was stuck has been ejected during this process. If the Shotshell has ejected and there is no jam, then properly clean the firearm as instructed in this manual and try different ammunition. You may now resume normal operation. If you still experience a jam, contact a qualified gunsmith or the Product Service Center.
6. If a stuck Shotshell is in the Chamber and does not eject after the above steps, or you experience a possible Bore obstruction then do not attempt to close the action. Remove the Barrel (refer to the Disassembly section of this owner’s manual). Contact a qualified gunsmith so that the gunsmith may remove the Shotshell and/or Bore obstruction and verify there is no damage to the firearm.



Do not attempt to remove a bore obstruction using a blank shotshell, or a shell from which the shot charge has been removed, or by shooting it out with another shotshell.



Never force a jammed action. This could cause a shotshell to explode resulting in death, serious injury or property damage to you or those around you.



Do not use a metal tool to attempt to remove an unfired shotshell because it could ignite the primer and fire or rupture sending fragments out of the ejection port with sufficient force that could cause death, serious injury or property damage to you or those around you.



Never pull the trigger if the bolt does not fully close to prevent a possible out of battery firing. If this happens, unload the firearm (refer to Unloading the Firearm section of this owner’s manual). Examine the shotshell that was in the chamber and check the chamber to ensure that there are no obstructions or debris in it.

UNLOADING THE FIREARM



WARNING: This product can expose you to chemicals, including lead, which is known to the State of California to cause cancer and birth defects or other reproductive harm. For more information go to www.P65Warnings.ca.gov.



Set the safety button to the “ON” (SAFE) position. During unloading, never allow your fingers or any other object to contact the trigger.

KEEP THE MUZZLE POINTED IN A SAFE DIRECTION AT ALL TIMES.

1- Pull the Operating Handle fully rearward, then allow it to move forward slowly to close the Action. This procedure will remove and eject the Shotshell in the Chamber, but will load a new one to the Chamber from the Magazine Tube.

2- To remove any remaining shells, repeat this procedure until the Magazine Tube is empty.

3- Once the Magazine Tube is empty, Action will stay back in the “OPEN” position when you pull the Operating Handle rearward.



After unloading always visually and physically inspect the chamber, elevator, and magazine tube to be certain all of the shotshells have been removed, and the firearm is completely unloaded.

DISASSEMBLY & MAINTENANCE



Before disassembling the firearm, set the safety button to the “ON” (SAFE) position and keep the muzzle pointed in a safe direction. Lock the action open, visually and physically check the chamber, elevator, and magazine tube to ensure the firearm is completely unloaded (Refer to the Unloading The Firearm section of this owner’s manual).



Wear eye protection during disassembly and cleaning to protect your eyes from oil spatter or spring loaded components.

DISASSEMBLY

Removing the Forearm;

1- Unscrew the Magazine Cap by turning it counter-clockwise. When it’s clear off the threads, slide it off the Magazine Tube.

2- Slide the Forearm forward to remove it from the Magazine Tube.

Removing the Barrel Assembly;

1- After removing the Forearm, pull the Operating Handle fully rearward. Action will stay back in "OPEN" position. Then, close the Action by pressing the Bolt Release Button.

2- While pushing the Bolt Assembly forward (towards the Barrel Assembly) with your thumb, pull the Barrel Assembly out of the Receiver, then slide the Barrel Assembly all the way off the Magazine Tube to remove it completely. Check FIG.DA6 for reference.

3- Ensure the Gas Piston remains in the Barrel Gas Cylinder. If the Gas Piston remains on the Magazine Tube after the Barrel is removed, slide the Gas Piston forward to remove it from the Magazine Tube and place it into the Barrel Gas Cylinder.

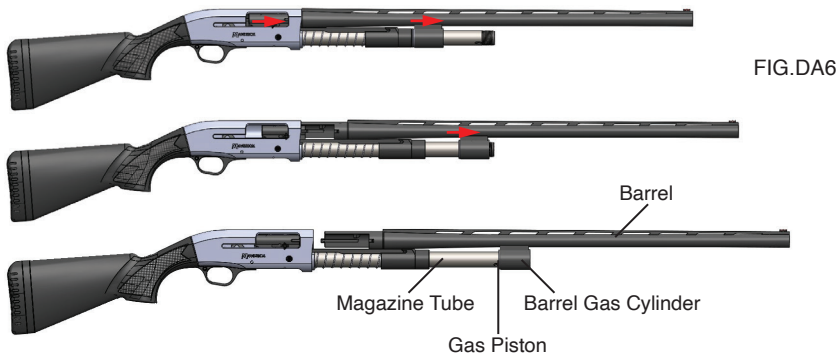

Removing the Action;

1- After removing the Barrel Assembly, slowly push and hold the Action (Action Arm Assembly and Bolt Assembly) back slightly into the Receiver.

2- Hold the Action in this position and move the Bolt Assembly to align the notch in the Bolt with the raised protrusion on the Operating Handle.

3- With the Bolt Notch and the Operating Handle correctly aligned, pull the Operating Handle straight out. Check FIG.DA1 for reference.

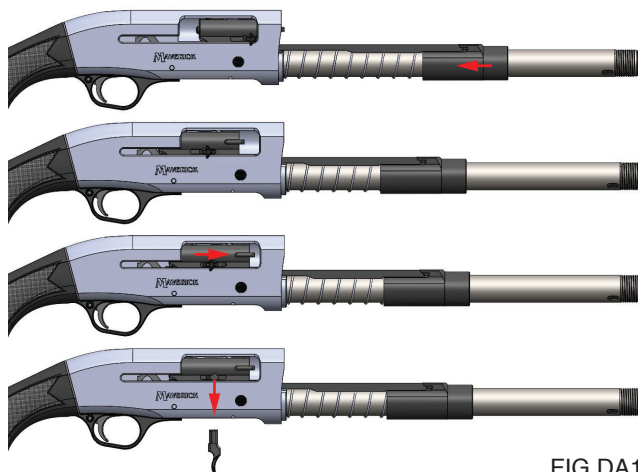

4- Slowly allow the Action to travel fully forward. Remove the Bolt Assembly and Action Arm Assembly through the barrel hole in the Receiver.

5- Once the Action is out of the Receiver, lift up the Bolt Assembly to remove it from the Action Arm Assembly. Then separate the Action Arm from the Action Arm Ring. Check FIG.DA2 for reference.

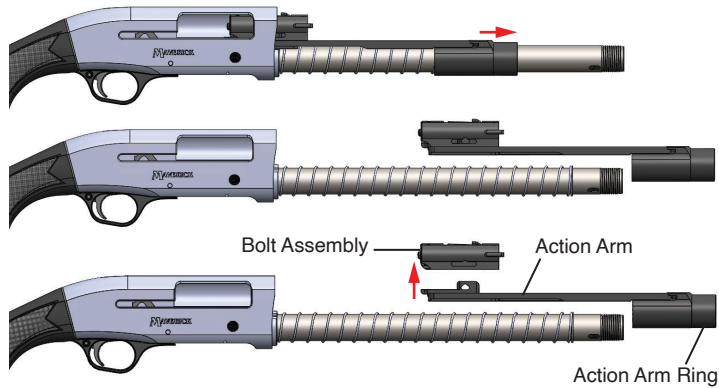

FIG.DA2

6- Slide the action spring forward off the magazine tube.

Removing the Trigger Housing;

1- After removing the Action, push out the Trigger Housing Retaining Pin using a punch no larger than $3/32$ " (2.5mm). The Pin can be pushed out from either direction.

2- Remove the Trigger Housing Assembly from the Receiver by sliding it forward and down, while pressing the Bolt Release Button. Check FIG.DA3 for reference.

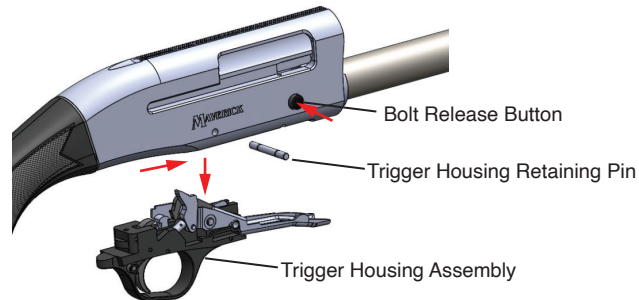

FIG.DA3

The Trigger Housing Assembly is a complex assembly and must not be disassembled. Disassembly should only be performed by the Product Service Center or a qualified gunsmith.



Never pull the trigger while the trigger housing assembly is removed from the receiver, as personal injury or damage to the trigger housing assembly may result.



Field disassembly is now complete. Further disassembly should only be performed by a qualified gunsmith or the Product Service Center. Improper disassembly or reassembly, alterations, modifications and/or repairs by a party other than Mossberg could compromise the safety or performance of your firearm, and could result in death, serious injury, or property damage to you or others and will void your warranty.



FIG.DA5

CLEANING AND LUBRICATION

With proper maintenance and care, your firearm will provide you with years of dependable service. Your firearm should be inspected and cleaned periodically to ensure that it remains in good condition. Clean and lubricate your firearm as soon as possible after use. This is especially important if your firearm has been exposed to moisture. For maximum performance and continued satisfaction with your firearm, periodic cleaning and lubrication are essential. Wear eye protection during cleaning.

To clean and lubricate your firearm, first disassemble it (refer to the Disassembly section of this owner's manual). Use the instructions and equipment provided with a quality firearm cleaning kit as well as the instructions in this owner's manual.



Always be sure that the firearm is unloaded (refer to the Unloading the Firearm section of this owner's manual) by visually and physically checking the chamber, elevator and magazine tube before cleaning your firearm. Be sure that the safety is in the "ON" (SAFE) position. Wear eye protection during cleaning and assembly to protect your eyes from oil splatter and spring loaded components.



Always make sure that no ammunition is located in the area where you clean your firearm. Cleaner-lubricant-preserved can affect the primer and powder in ammunition and cause it to malfunction. This could result in a shotshell being pushed into the barrel of your firearm and getting stuck. Firing another round with a shotshell stuck in the barrel could cause the barrel to burst and result in death, serious injury, or property damage to you or those around you.



WARNING: This product can expose you to chemicals, including lead, which is known to the State of California to cause cancer and birth defects or other reproductive harm. For more information go to www.P65Warnings.ca.gov.

Normal use requires only that the mechanisms be free of excessive shooting residue. All metal parts should be cleaned with an appropriate firearm cleaning solvent. Very little lubrication other than a light oiling of internal and external surfaces to prevent rust is needed. Use only lubricants specifically designed for firearms. Avoid the use of abrasives which may damage the metal finish.

To ensure optimum performance, Mossberg recommends thorough cleaning of your firearm after every 500 rounds. However, unusually dusty, dirty, or harsh weather conditions, or use of ammunition which leaves significant powder residue may require more frequent cleaning.

If the firearm is to be stored for a long period of time, it should be thoroughly cleaned and oiled. Do not plug the barrel or store in a fabric-lined case that will absorb lubricant from the firearm, as this may result in corrosion to the unprotected metal surfaces.

Over-lubrication should be avoided during below freezing conditions. Many lubricants thicken in low temperatures which could affect the operation of the firearm. Exposure to unfavorable weather, or moisture from condensation, requires additional care to prevent corrosion of the firearm.

BARREL CLEANING

Scrub the bore and chamber with solvent and follow with cleaning patches until the barrel is clean. A final pass with a lightly oiled patch will provide a protective coating. A stiff brass bristle brush is useful for removing stubborn deposits.

NOTE: During cleaning of the barrel, be certain a choke tube is properly installed. This will avoid residue build-up on threads.



Make sure the barrel is free of obstructions and excessive lubricant after cleaning. Be sure not to leave cleaning patches, excessive oil or grease in the bore. Obstructions of any kind can cause damage to the firearm and could cause death, serious injury, or property damage to you or those around you.

ACTION CLEANING

Using a solvent, clean all components of the Action, including the Bolt Assembly and Action Arm Assembly (Action Arm and Action Arm Ring) to remove accumulated residue. Action parts will remain cleaner, longer, if lubrication is used sparingly. Check FIG.DA4 for reference.

RECEIVER CLEANING

Clean the inside of the Receiver with a rag or soft bristle brush, giving special attention to the tracks which guide the Bolt Assembly and Action Arm Assembly. Place a few drops of light oil in these tracks when clean. Care should be taken when cleaning the exterior surfaces of the Receiver to prevent cosmetic damage. Never use a brush with metal bristles, as this could remove the protective coating on the Receiver.

TRIGGER HOUSING ASSEMBLY CLEANING

Brush loose residue from the Trigger Housing Assembly with a soft bristle brush. Never use a brush with metal bristles, as this could remove the protective coating found on and within the Trigger Housing Assembly.



Never pull the trigger while the trigger housing is removed from the receiver, as personal injury or damage to the trigger housing may result.

GAS SYSTEM COMPONENT CLEANING

The gas system includes the Magazine Tube, Gas Piston, Action Spring, and Gas Cylinder portion of the Barrel.

These parts should be thoroughly cleaned using a solvent. A stiff brass bristle brush is useful for removing stubborn deposits on the Gas Piston, Magazine Tube and Gas Cylinder.

Using a rag and solvent, remove deposits from the Magazine Tube, and Action Spring.

Using a stiff brass bristle brush and solvent, remove deposits from the inside and outside of the Gas Piston. It is critical that this component is free of deposits to ensure proper function of your firearm.

NOTE: The Gas Piston may have an outer piston ring installed by the factory. This outer ring should not be removed during disassembly or cleaning. After cleaning ensure outer piston ring can rotate freely.

Using a stiff brass bristle brush and solvent, thoroughly clean the inside of the Barrel Gas Cylinder, making sure to remove all deposits to ensure that the Gas Piston can move freely through its full range of motion.

Apply a light coat of gun oil to all metal parts and then wipe thoroughly with a dry cloth. Excess oil will accelerate the build up of carbon residue in the gas system and may have a negative effect on the firearm's performance.

Camouflage firearms: Caution should be exercised to avoid exposure of camouflage patterns to strong solvents or insect repellants.

RE-ASSEMBLY

Re-Assembling the Trigger Housing Assembly;

1- Insert the Trigger Housing Assembly into the Receiver by sliding it up and backwards, while pressing the Bolt Release Button. Align the corresponding holes of the Trigger Housing and the Receiver.

2- Push in the Trigger Housing Retaining Pin until it is flush with the sides of the Receiver.

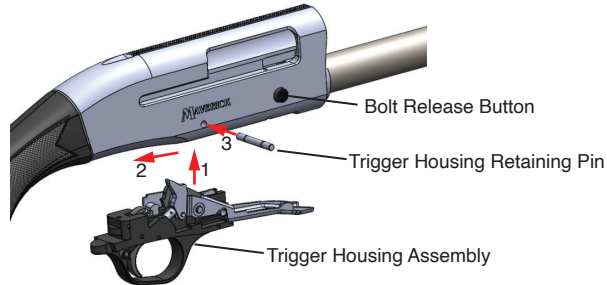

FIG.DA7

Re-Assembling the Action;

1- Slide the Action Spring onto the Magazine Tube.

2- Place the Bolt Assembly on its location on top of the Action Arm. Make sure that orientation is correct.

3- Insert Action Arm's front edge into its housing on the Action Arm Ring. Firmly press them together to align the Action Arm with its Ring. See FIG.DA4

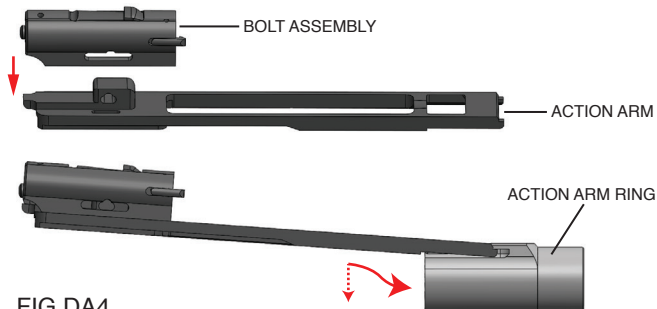

FIG.DA4

3- Slowly slide the Action (Bolt Assembly, Action Arm, and Action Arm Ring) on the Magazine Tube, with Magazine Tube going through the Action Arm Ring, and push the Bolt Assembly rearward into the Receiver just far enough for the Operating Handle slot to become fully visible through the Ejection Port.

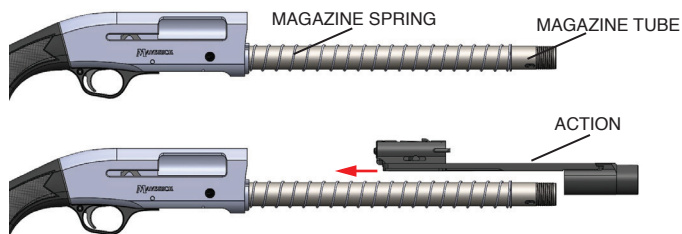

FIG.DA8

4- Once Bolt Assembly is in the Receiver, looking through the Ejection Port, align the notch in the Action Arm with the corresponding notch of the Bolt Assembly. Then push the Operating Handle through the aligned notches, with the dome of the Operating Handle protrusion facing up. See FIG.DA9.

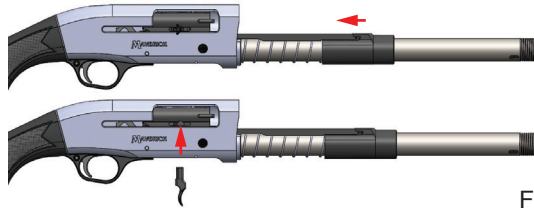

FIG.DA9

Re-Assembling the Barrel;



When reinstalling the barrel onto the firearm, YOU MUST ensure that the gas piston is present in the gas cylinder portion of the barrel prior to installing the barrel. Failure to do so may result in a dangerous malfunction, damage to the firearm and could cause death, serious injury, or property damage to you or those around you when the firearm is fired. The firearm's owner must accept full responsibility for the correct reassembly and functioning of the firearm after any disassembly or replacement of parts.

- 1- The Action must be in the closed position (Bolt Assembly fully forward). (Refer to the Closing the Action section of this owner's manual.)
- 2- Fully seat the Gas Piston into the Barrel Gas Cylinder. Check FIG.UA2 for reference.
- 3- Align the Barrel to the Receiver as shown in FIG.UA3 and slide the Barrel Gas Cylinder over the Magazine Tube.
- 4- When the Barrel Extension reaches the gap between the Receiver and the Bolt Assembly, push the Bolt Assembly forward (towards the Barrel Assembly) with your thumb while pulling the Barrel Assembly rearward (towards the Receiver) until the Barrel Extension is fully seated inside the Receiver. Check FIG.UA3 for reference.

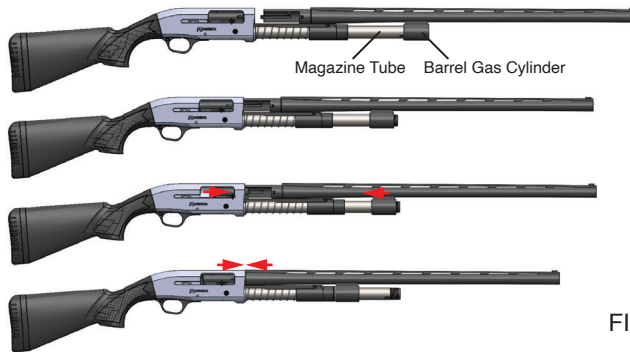

FIG.UA3

Re-Assembling the Forearm;

- 1- Slide the Forearm over the Magazine Tube until it sits flush against the Receiver. Check FIG.UA4 for reference.
- 2- Screw the Magazine Cap to the front of the Forearm, by placing it on the tip of Magazine Tube, then turning it clockwise. Screw it finger tight, do not over tighten !



Be certain to check your firearm for proper functioning before firing any live ammunition (refer to the Function Testing section of this Owner's Manual).

FUNCTION TESTING



AFTER PERFORMING ANY WORK ON YOUR FIREARM SUCH AS CLEANING, DISASSEMBLY, OR INSTALLATION OF ANY ACCESSORY, CHECK YOUR FIREARM FOR PROPER FUNCTIONING BEFORE USING AND/OR FIRING ANY LIVE AMMUNITION.



Set the safety button to the “ON” (SAFE) position and keep the muzzle pointed in a safe direction. Lock the action open, visually and physically check the chamber, elevator, and magazine tube to ensure the firearm is completely unloaded (Refer to the Unloading The Firearm section of this owner’s manual).



KEEP THE MUZZLE POINTED IN A SAFE DIRECTION AT ALL TIMES THROUGHOUT THE FOLLOWING STEPS! FAILURE TO DO SO COULD CAUSE DEATH, SERIOUS INJURY, OR PROPERTY DAMAGE TO YOU OR THOSE AROUND YOU IF THE FIREARM HAS NOT BEEN PROPERLY UNLOADED AND FIRES WHILE YOU ARE TESTING ITS FUNCTION!

1. Move the Safety Button to the “ON” (SAFE) position.
2. Grasp the Operating Handle and pull the Bolt fully rearward. It should lock in the open position.
3. With fingers and other objects clear of the Ejection Port, press the Bolt Release and allow the Bolt to move forward under spring pressure. It should lock in the fully closed position. Repeat this procedure several times to check for free movement of the Action Assembly.
4. With the Action closed and the Safety Button in the “ON” (SAFE) position, pull the Trigger fully rearward. The Hammer should not fall (NO FIRE).
5. Remove your finger from the Trigger. Move the Safety Button to the “OFF” (FIRE) position. The Hammer should not fall (NO FIRE).
6. Move the Safety Button to the “OFF” (FIRE) position.
7. Pull the Trigger rearward. The Hammer should fall (FIRE).
8. Open the Action. Move the Safety Button to the “ON” (SAFE) position.



IF YOUR FIREARM DOES NOT PERFORM AS DESCRIBED IN ANY OF THE ABOVE STEPS, CONTACT THE PRODUCT SERVICE CENTER IMMEDIATELY. DO NOT ATTEMPT TO LOAD OR USE THE FIREARM.



Firearms are complex mechanisms. Any modification, alteration, or improper fitting of parts may result in a dangerous malfunction, damage to the firearm, and could cause death, serious injury or property damage to you or those around you. The firearm’s owner must accept full responsibility for the correct reassembly and functioning of the firearm after any disassembly or replacement of parts.

ACCESSORIES & ADJUSTMENTS

STOCK SPACER SYSTEM



Before performing any stock adjustments on your firearm, set the safety button to the "ON" (SAFE) position and keep the muzzle pointed in a safe direction. Lock the action open, visually and physically check the chamber, elevator, and magazine tube to ensure the firearm is completely unloaded (Refer to the Unloading The Firearm section of this owner's manual).



Wear eye protection during disassembly and assembly to protect your eyes from oil spatter or spring loaded components.

The MAVERICK SA™ stock is user adjustable for three attributes: length of pull (LOP), rise/drop at the heel (DAH) and right/left or no cast (CAST). This is achieved by using the various spacers included with this firearm.

LENGTH OF PULL (LOP)

The MAVERICK SA stock is adjustable for length of pull (LOP). This is accomplished by the use of 1/2 inch and 1/4 inch Spacers. The user can adjust LOP by removing the Recoil Pad and installing the correct combination of LOP Spacers and Recoil Pad Screws per the table below. Do not over tighten the Recoil Pad Screws when reassembling. Note the desired LOP and spacers installed affects the length of the screws used in the recoil pad.

Length of pull	LOP Spacer	Screws
13"	None	Short
13 1/4"	1/4"	Short
13 1/2"	1/2"	Short
13 3/4"	1/2" & 1/4"	Long
14"	2X 1/2"	Long
14 1/4"	2X 1/2" & 1X 1/4"	Long
**Long screws come installed, short screws come in the spacer accessory kit included with your firearm.		

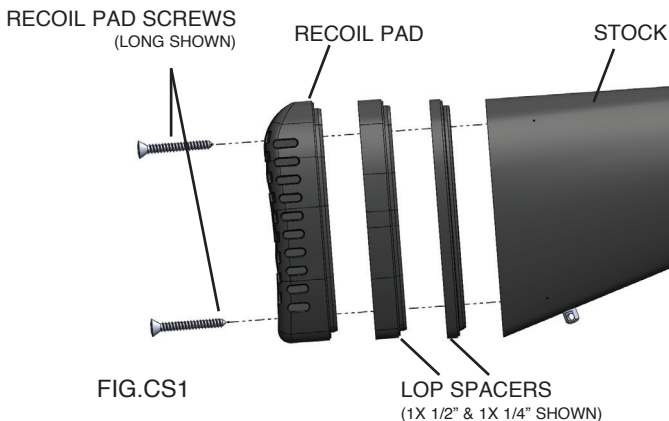

After performing any work on your firearm such as cleaning, disassembly, or installation of any accessory, check your firearm for proper functioning before firing any live ammunition.

DAH (DROP AT HEEL) AND CAST SPACERS

Vertical and horizontal positions of the Maverick® SA™ stock is adjustable. This firearm is set up from the factory with no drop nor cast. DAH and Cast Spacers are included in the accessory pack. Each Spacer is marked with its intended alteration to the Stock. The user can adjust drop/rise and cast by installing the correct combination of Spacers per the following instructions. Check FIG.CS2 for reference.

- 1- Using a PH2 screwdriver, loosen Recoil Pad Screws. The Screws can remain in the Recoil Pad. (A drop of oil on screw locations will avoid damage to the recoil pad)
- 2- Remove Recoil Pad and LOP Spacers from the Stock by simply pulling them back.
- 3- Using a long 1/2" (13mm) hex nut driver, unscrew the Stock Screw to remove it (along with the washer and the ring on it) from the inside of the Stock.
- 4- Remove the Stock from the Receiver by pulling it back.
- 5- Now you can install/remove DAH and Cast Spacers. Place the selected Spacers on the back of the Receiver, text side facing out. You can install a DAH and a Cast Spacer together.
- 6- Reinstall the Stock back to Receiver using the 1/2" (13mm) hex nut driver. Do not over-tighten the Stock Screw.
- 7- Reinstall the Recoil Pad and LOP Spacers back to Stock (you can install/remove LOP Spacers at this stage). Do not over-tighten the recoil pad screws.



Make sure to have the plain spacer installed on walnut stocks at all times, in order to minimize the possibility of cracking/breaking the walnut stock.



After performing any work on your firearm such as cleaning, disassembly, or installation of any accessory, check your firearm for proper functioning before firing any live ammunition.



FIG.CS2

EXTRA GAS PISTON & GAS PISTON SELECTION



Before performing a gas piston change, set the safety button to the “ON” (SAFE) position and keep the muzzle pointed in a safe direction. Lock the action open, visually and physically check the chamber, elevator, and magazine tube to ensure the firearm is completely unloaded. (Refer to the Unloading the Firearm section of this manual)

This shotgun is equipped with an additional Gas Piston. The additional Gas Piston (Fast or Heavy (Blue)) is located inside the Choke Tube Box, under the Choke Tube Separator. See FIG.CS3.

The Fast or Heavy (Blue) Gas Piston is recommended to be used specifically with 1500 fps+ or 1 3/4 oz+ ammunition. This is to regulate the pressure inside the shotgun and to provide increased shooting performance and to reduce the felt recoil.

Change the Gas Piston by following the steps below:

- 1- Remove the Barrel Assembly (refer to the Disassembly section of this owner’s manual).
- 2- Remove the Gas Piston from the Barrel Gas Cylinder (refer to the Disassembly section of this owner’s manual).
- 3- Install the alternate Gas Piston (refer to the Re-Assembly section of this owner’s manual).
- 4- Re-assemble the Barrel Assembly (refer to the Re-Assembly section of this owner’s manual).



The Fast or Heavy (Blue) Gas Piston may cause the shotgun to malfunction if used with standard / light load ammunition. Utilize the Regular (Silver) Gas Piston while operating with standard / light load ammunition.



When reinstalling the barrel onto the firearm, YOU MUST ensure that the gas piston is present in the gas cylinder portion of the barrel prior to installing the barrel. Failure to do so may result in a dangerous malfunction, damage to the firearm and could cause death, serious injury, or property damage to you or those around you when the firearm is fired. The firearm’s owner must accept full responsibility for the correct reassembly and functioning of the firearm after any disassembly or replacement of parts.

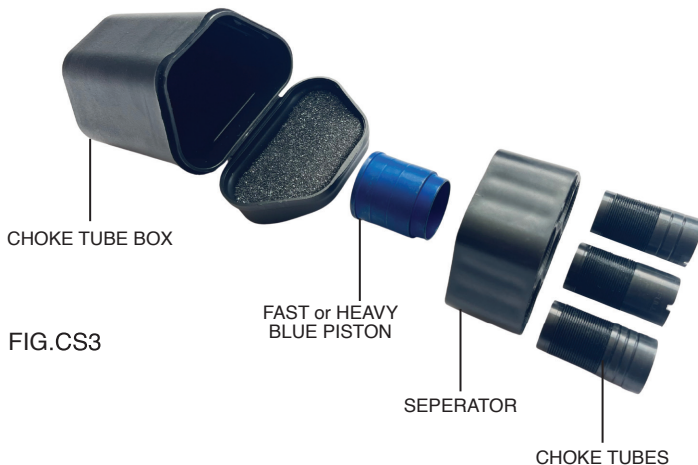

CHOKE TUBES



Before removing or installing any choke tube, set the safety button to the "ON" (SAFE) position and keep the muzzle pointed in a safe direction. Lock the action open, visually and physically check the chamber, elevator, and magazine tube to ensure the firearm is completely unloaded (Refer to the Unloading The Firearm section of this manual).



Do not use bent or deformed choke tubes as these may result in tube or barrel damage upon firing which could cause serious personal injury to you or those around you. Inspect choke tubes periodically to insure they are properly installed and in good condition. Pay special attention to the threaded end of the choke tube to be certain it is not deformed or dented.



Never fire this firearm without a choke tube properly installed. Failure to do so will damage the precision threads on the inside of the barrel. Firing this firearm with loose choke tubes may lead to damage to the choke tube and barrel, as well as serious personal injury to you or those around you.

CARE & CLEANING: The precision threads on your choke tube should be kept clean and lightly oiled at all times.

NOTE: During cleaning of the barrel, be certain a choke tube is properly installed. This will avoid residue build-up on threads.

Choke tubes provided with your firearm vary per model. The Maverick SA™ comes with either an extended choke tube or flush mounted Accu-Choke™ installed.

These choke tubes are designed for use with Lead, Steel, and other non-toxic shot. Each durable tube is clearly marked, as a guide, with the pattern it will produce.

TO REMOVE THE CHOKE TUBE:

For extended choke tubes, loosen the choke tube provided by hand, turning it counterclockwise. Place the choke tube on a clean, dry surface.

For flush mounted Accu-Choke™ tubes use the wrench provided, turning it counterclockwise. Place the choke tube on a clean, dry surface.

TO INSTALL THE CHOKE TUBE:

For extended choke tubes, screw the choke tube clockwise into the barrel by hand and then tighten until snug. Do not use excessive force when installing.

For flush mounted Accu-Choke™ tubes use the wrench provided, turning it clockwise until snug. Do not use excessive force when installing.



Choke tube tightness should be checked periodically to avoid damage to the choke, firearm, and to prevent injury to you or those around you.

* Lead, steel, and other non-toxic shot patterns will vary substantially depending on shell length, shot size, brand of ammunition, and the individual barrel. The shooter is urged to conduct pattern tests before field use.

ACCU-CHOKE™ TUBES

GAUGE	ITEM #	LEAD SHOT PATTERN*	Extended Or Flush Fitting
12	95235	Skeet	Flush
12	95200	Improved Cylinder	Flush
12	95170	Improved Cylinder	Extended, Ported
12	95195	Modified	Flush
12	95180	Modified	Extended, Ported
12	95245	Improved Modified	Flush
12	95190	Full	Flush
12	95240	X-Full	Flush
12	95268	XX-Full Turkey (Lead Only)	Extended, Ported
12	95267	XX-Full Turkey (Lead Only)	Extended

DRILLED & TAPPED RECEIVER FOR PICATINNY RAIL



Before performing any sight adjustments on your firearm, set the safety button to the “ON” (SAFE) position and keep the muzzle pointed in a safe direction. Lock the action open, visually and physically check the chamber, elevator, and magazine tube to ensure the firearm is completely unloaded (Refer to the Unloading The Firearm section of this manual).

This shotgun’s Receiver top section is machined to allow the mounting of a Mossberg Picatinny Rail.

Using a proper thin screwdriver remove the Tap Setscrews. Be sure to keep the Setscrews for future re-installation. While re-installing, keep them flush with the top of the Receiver. Apply a drop of low strength thread locking compound on Setscrew threads while re-installing.

Using the wrench and installation screws provided with the Mossberg Picatinny Rail, fasten the Picatinny Rail to the Receiver. Check to ensure that the Screws are of proper length and do not protrude into the inside of the Receiver. The screws may need to be shortened by filing or grinding in order to get a proper fit.



After performing any work on your firearm such as cleaning, disassembly, or installation of any accessory, check your firearm for proper functioning before firing any live ammunition.

CABLE LOCK



Before installing the cable lock, move the safety button to “ON/SAFE” position. Visually and physically inspect the chamber, elevator, and magazine tube to be certain the firearm is completely unloaded. Keep the muzzle pointed in a safe direction while opening the action.



Do not close the action with the cable lock installed. This may result in damage to your cable lock and firearm.



Store your cable lock keys in a separate location.

To install the cable lock:

1. Ensure the action remains locked in the open position to install your cable lock.
2. Unlock the cable lock with the key provided, leave the key in the lock body.
3. Pass the free end of the cable through the ejection port and down through in front of the elevator in the loading port.
4. Align the free end of the cable with the open hole on the lock body. Press and hold firmly in place.
5. Turn the key counter clockwise until locked. Remove the key.
6. Tug on lock body to be sure the cable lock is secure. If not locked, reinsert the key and repeat steps 4 and 5.
7. To unlock the cable lock, insert the key into the lock body. Turn clockwise and pull on the lock body until the cable releases.

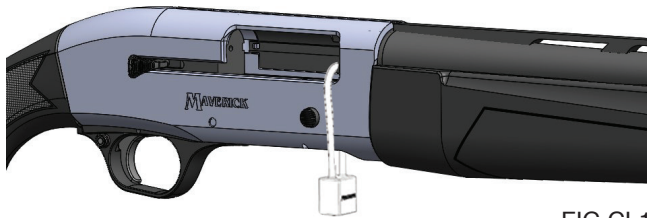

FIG.CL1

CORRECT INSTALLATION OF CABLE LOCK



Ensure the cable lock is installed correctly as shown in FIG.CL1. Improper installation of the cable lock or storage of your firearm could cause, death, serious injury or property damage to you or those around you.

STORAGE



Always store this firearm securely and unloaded. Failure to do so could result in an unintentional discharge.



Use the locking device supplied with the firearm for storage. The use of a locking device or cable lock is only one aspect of responsible firearms storage (see Cable Lock section of this owner's manual).



While locking devices are an important aid to security measures, they are not a substitute for safe firearm handling and proper storage. Mechanical and locking devices can fail and/or be bypassed with enough time, knowledge, determination and equipment.



Keep out of reach of children. Firearms should be stored unloaded in a location that is secure and inaccessible to children and any other unauthorized person, with ammunition locked securely in a different location.



Never act in an irresponsible manner or ignore any established rules of safety when using or storing firearms.

After unloading, cleaning and lubrication and function testing this firearm as instructed in this owner's manual, follow these instructions on storage to properly and securely store your firearm:

1. Select a safe and secure location for storage, one that conforms to the instructions and recommendations of this manual and all applicable laws, including but not limited to use of the cable lock provided with this firearm (see Cable Lock section of this owner's manual).
2. If possible, do not store the firearm in the factory-supplied case as moisture may collect and cause damage.
3. If you plan on storing the firearm for extended periods of time between uses, clean and lubricate the firearm per instructions in this manual every six months (see Cleaning and Lubrication section of this owner's manual).

SERVICE INSTRUCTIONS

Should your firearm or any component of your firearm require service, ship your entire firearm (please do not send components only), via your chosen carrier, postage paid (we do not accept C.O.D. shipments), following these instructions:

Repairs in the U.S.

For faster repair service, please start the process by filling out our Service Request Form online at <http://www.mossberg.com/service> prior to shipping your firearm.



- **Make absolutely certain your firearm is unloaded.**
- **Do not send ammunition with your firearm.**
- Remove all accessories from your firearm such as scopes, slings, scope mounts, etc.
- Ship your firearm in a suitable container, packaging it securely to prevent parts from shifting and/or damage during shipping.
- Include a note with a clear description of the service you wish us to perform, your complete return shipping address (no P.O. boxes please), your daytime telephone number and your e-mail address (if available).
- It is advisable to place your correspondence inside your shipping container when shipping.

SHIPPING ADDRESS

MPSC
1001 Industrial Blvd.
Eagle Pass, TX 78852

If you have any service related questions, please contact the Product Service Center at (800) 363-3555 or service@mossberg.com

TO ORDER PARTS

To order parts from the Product Service Center, you can fax, phone, email, or mail your order to one of the below numbers/addresses.

Fax Number: (203) 230-5420

Phone Number: (800) 363-3555

E-mail Address: service@mossberg.com

Mailing Address: Mossberg Product Service Center
1001 Industrial Blvd.
Eagle Pass, TX 78852
Attn: Order Department

Please provide your name, address, city, state, zip, your daytime phone number and e-mail (if available). The Product Service Center will need the Model Number, Serial Number, Gauge/Caliber, Finish, Item Number, and Part Name. There is a \$7.50 (U.S.) minimum parts order charge. Most major credit cards, money orders, and bank drafts are accepted.

Service outside of the U.S.A.

For Mossberg firearm parts and service requirements outside of the United States, customers are requested to contact the closest Mossberg stocking dealer/distributor.

**MOSSBERG INTERNATIONAL, INC. WARRANTY
12 GAUGE AUTOLOADING SHOTGUN
ONE (1) YEAR LIMITED WARRANTY**

Limited Warranty: Mossberg International™, Inc. ("Mossberg") warrants to you, the original retail purchaser of a new Mossberg International™ Autoloading Shotgun (the "Mossberg firearm"), that the Mossberg firearm will be free of defects in material or manufacture for a period of one (1) year from the date of your purchase of the new Mossberg firearm (the "Warranty Period") in the United States or Canada. This is the only express warranty on the Mossberg firearm.

MOSSBERG MAKES NO OTHER WARRANTIES OF ANY KIND OR CONDITIONS, INCLUDING, BUT NOT LIMITED TO ANY IMPLIED WARRANTY OF MERCHANTABILITY OR FITNESS FOR A PARTICULAR PURPOSE.

The implied warranties of merchantability and fitness for a particular purpose, and all other warranties not expressly made herein, are expressly disclaimed. All disclaimers and limitations of liability shall still apply even if the limited remedy of repair or replacement fails of its essential purpose. There are no warranties which extend beyond the description on the face hereof. Any action against Mossberg and/or any Mossberg affiliates based on an alleged breach of this limited warranty must be brought within one (1) year of the claimed breach.

This Limited Warranty gives you specific legal rights, and you may have other rights that vary from State to State.

Purchaser's Remedy: During the Warranty Period, Mossberg will, at its sole option and discretion, (1) repair the Mossberg firearm or any part thereof that, upon examination and testing by Mossberg, does not conform to the Limited Warranty without charge to you for parts or labor, or (2) replace the Mossberg firearm with a new or similar model. THIS REMEDY SHALL BE YOUR EXCLUSIVE AND SOLE REMEDY FOR ANY BREACH OF WARRANTY. MOSSBERG SHALL NOT BE RESPONSIBLE FOR ANY OTHER EXPENSES, LOSSES, OR INCONVENIENCE THAT YOU MAY SUSTAIN AS A RESULT OF THE PURCHASE, USE, MALFUNCTION, OR DEFECTIVE CONDITION OF THE MOSSBERG FIREARM. Mossberg reserves the right to inspect, examine, and/or test the Mossberg firearm to assess any claim made under the Limited Warranty.

EXCLUSIONS: THIS WARRANTY DOES NOT COVER THE SURFACE FINISH OF ANY MATERIAL, THE COSMETIC APPEARANCE OF THE MOSSBERG FIREARM, OR ANY DAMAGE CAUSED BY:

- (1) NORMAL WEAR AND TEAR;
- (2) FAILURE TO PERFORM PROPER CARE AND MAINTENANCE;
- (3) ACCIDENTS, ABUSE, OR NEGLIGENCE;
- (4) BARREL OR BORE OBSTRUCTIONS;
- (5) FAILURE TO FOLLOW THE INSTRUCTIONS AND WARNINGS THAT ACCOMPANY THE MOSSBERG FIREARM;
- (6) THE USE OF DEFECTIVE, NON-SAAMI STANDARD, REMANUFACTURED, HAND-LOADED, AND/OR RELOADED AMMUNITION;
- (7) THE USE OF INCORRECT AMMUNITION (E.G., WRONG GAUGE);
- (8) DISASSEMBLY BEYOND THE INSTRUCTION OF THIS MANUAL;
- (9) CRIMINAL, NEGLIGENT, OR IMPROPER USE; OR
- (10) OTHER FACTORS BEYOND MOSSBERG'S CONTROL.

IN ADDITION, ANY UNAUTHORIZED REPAIRS, ALTERATIONS, OR MODIFICATIONS TO THE MOSSBERG FIREARM WILL AUTOMATICALLY VOID THE LIMITED WARRANTY.

(CONTINUED ON NEXT PAGE)

LIMITATION OF DAMAGES: EXCEPT WHERE PROHIBITED BY LAW, MOSSBERG, ITS OFFICERS, DIRECTORS, SHAREHOLDERS, EMPLOYEES, OR AGENTS WILL NOT BE LIABLE FOR ANY LOSS OR DAMAGE WHATSOEVER ARISING FROM THE USE OF THIS MOSSBERG FIREARM, WHETHER DIRECT, INDIRECT, SPECIAL, INCIDENTAL, CONSEQUENTIAL, OR PUNITIVE, REGARDLESS OF THE LEGAL THEORY ASSERTED, INCLUDING CONTRACT, WARRANTY, NEGLIGENCE, OR STRICT LIABILITY. SOME JURISDICTIONS DO NOT ALLOW LIMITATIONS ON HOW LONG AN IMPLIED WARRANTY LASTS, OR THE EXCLUSION OF INCIDENTAL OR CONSEQUENTIAL DAMAGES, SO THE ABOVE LIMITATIONS MAY NOT APPLY TO YOU.

Warranty Service: To obtain service under this Limited Warranty, you must follow the instructions found in the "Service Instructions" section of the Owner's Manual and return the Mossberg firearm to the authorized Product Service Center. You are responsible for all shipping costs to the Product Service Center. Mossberg will not accept COD shipments of any Mossberg firearm for service. After repair or replacement under warranty, the Mossberg firearm or a similar model will be returned to you, return postage paid by Mossberg. If we replace the Mossberg firearm, we will keep the firearm that you returned to Mossberg, and you hereby relinquish any and all rights in such returned firearm.

Modification of Warranty: No agent, representative, distributor, or authorized dealer of Mossberg firearms has any authority to modify the terms or conditions of the Limited Warranty in any way. The Limited Warranty may only be modified in writing by an authorized officer of Mossberg.

THIS LIMITED WARRANTY IS EFFECTIVE JANUARY 1, 2026

EXPLODED VIEW & PARTS LIST



PART NO#	PART DESCRIPTION	PART NO#	PART DESCRIPTION
01	RECOIL PAD SCREW	19	ACTION ARM
02	RECOIL PAD	20	ACTION ARM RING
03	LOP SPACER	21	ACTION SPRING
04	STOCK SCREW	22	MAGAZINE FOLLOWER
05	STOCK SCREW RING	23	MAGAZINE TUBE
06	STOCK SCREW WASHER	24	MAGAZINE TAP
07	SLING STUD (STOCK)	25	MAGAZINE CAP
08	STOCK	26	MAGAZINE SPRING
09	DAH/CAST SPACER	27	FOREARM
10	RECEIVER	28	RELEASE BUTTON PIN
11	TAP SCREW	29	CARRIER LATCH PIN
12	OPERATING HANDLE	30	CARRIER LATCH
13	BOLT ASSEMBLY	31	CARRIER LATCH SPRING
14	GAS PISTON	32	RELEASE BUTTON SPRING
15	O-RING (BARREL GAS CYLINDER)	33	BOLT RELEASE BUTTON
16	BARREL ASSEMBLY	34	TRIGGER HOUSING RETAINING PIN
17	FRONT SIGHT	35	TRIGGER HOUSING ASSEMBLY
18	ACCU-CHOKE TUBE		

NOTES

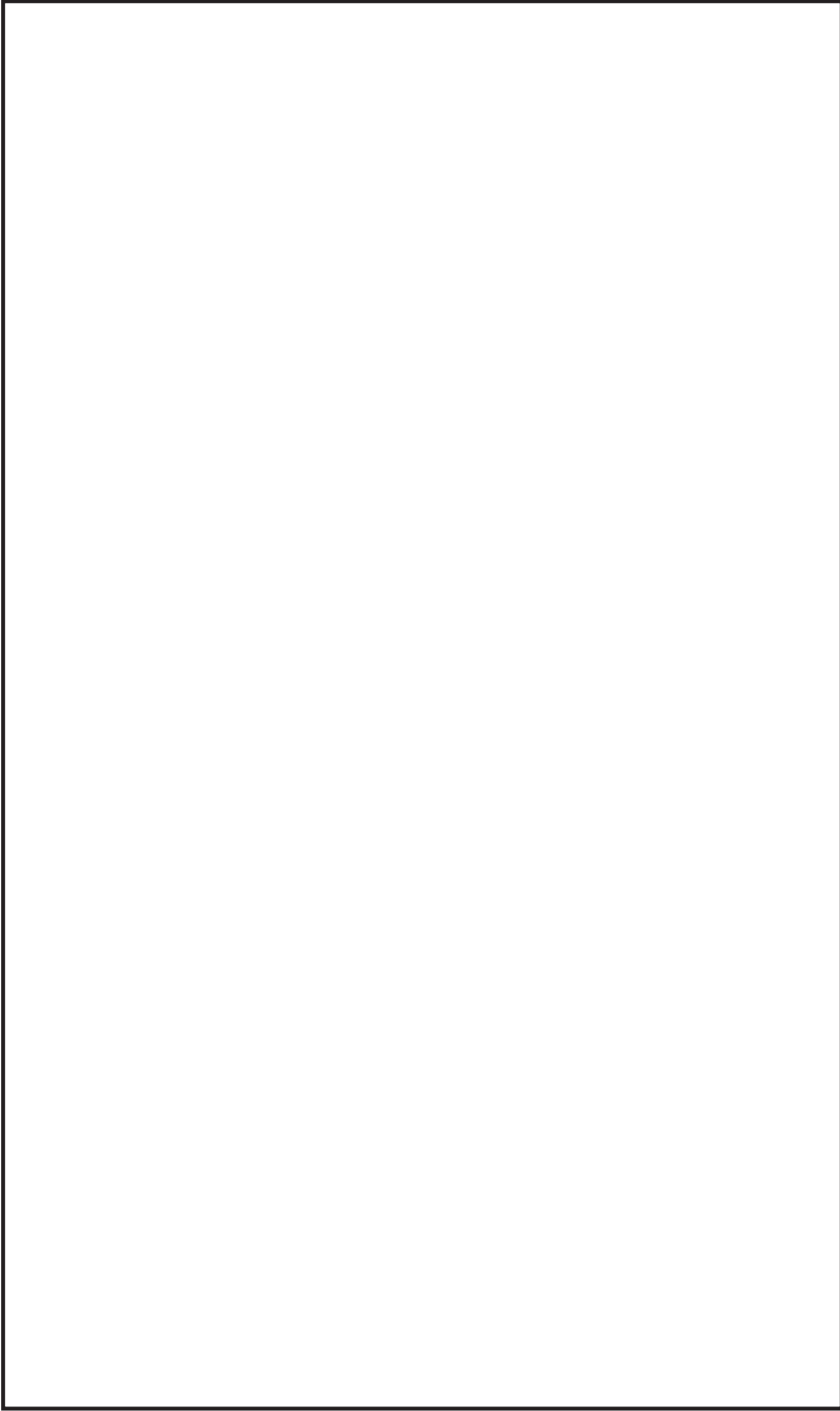

NOTES

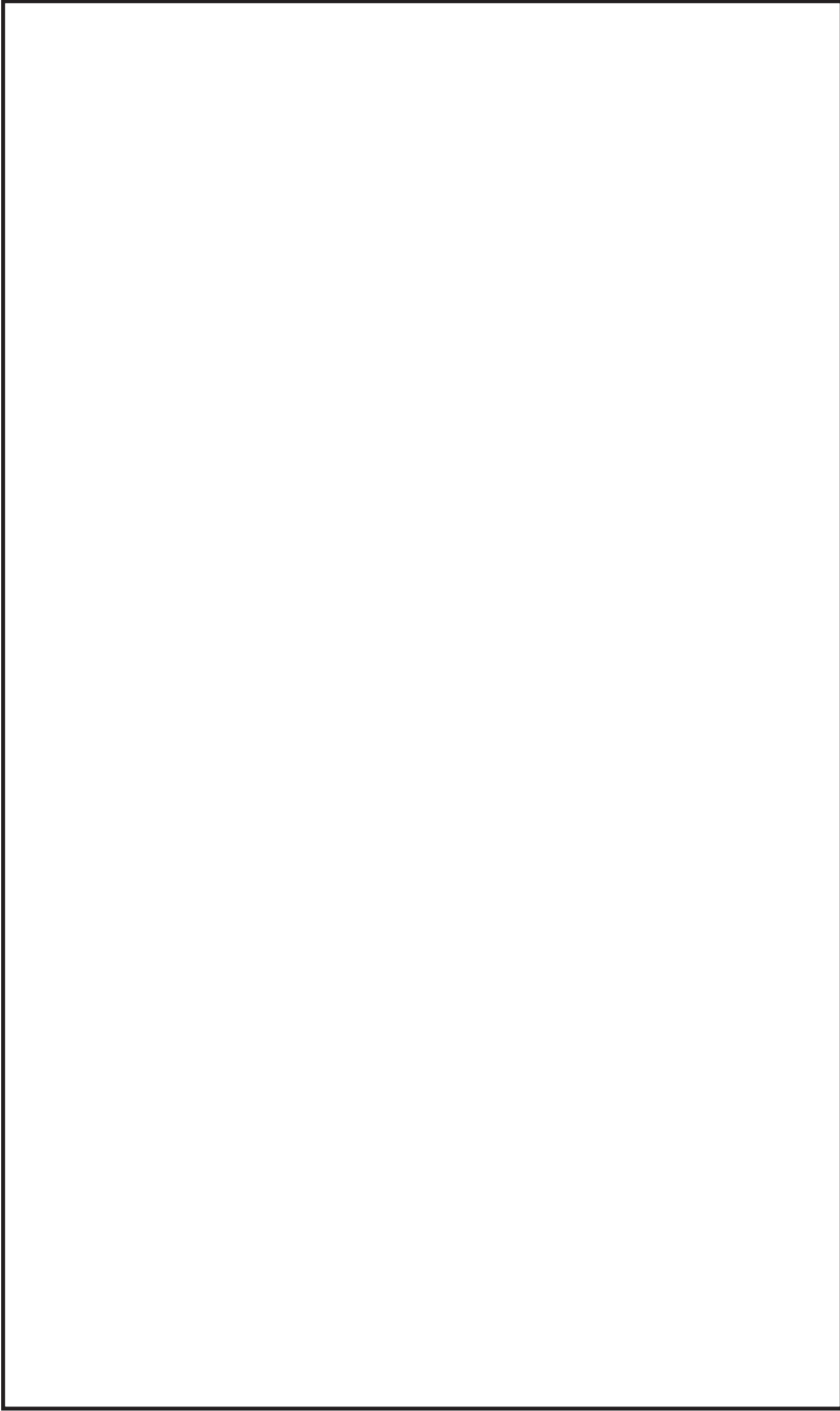

NOTES

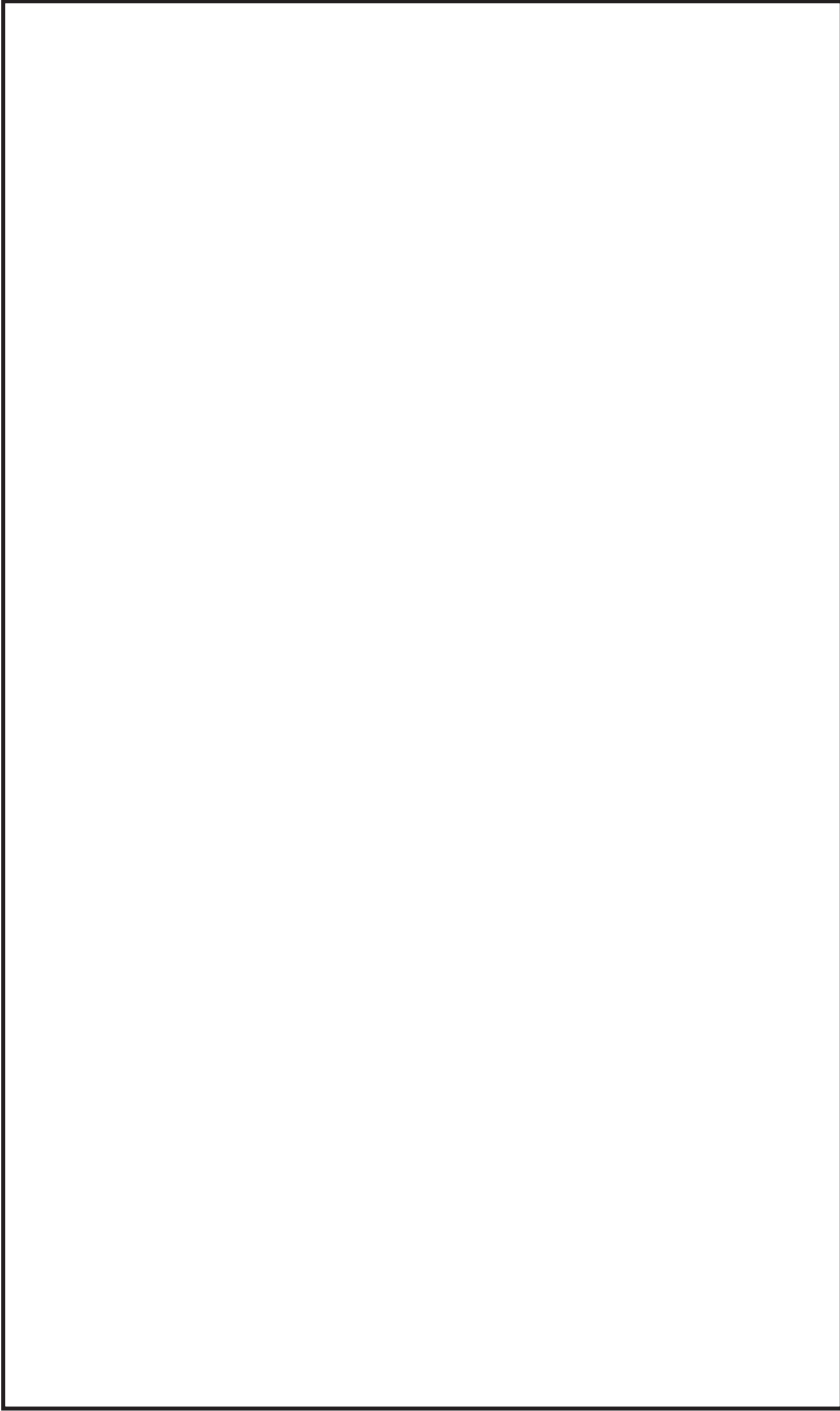

FIREARMS SAFETY DEPENDS ON YOU. MAKE NO MISTAKE ABOUT IT!

From the time an individual picks up a firearm, that individual shooter becomes a part of a system over which he or she has complete control. He or she is the only part of the system that can make a gun safe – or unsafe. Hunting and target shooting are among the safest of all sports. This booklet is intended to make them even safer – by re-emphasizing and reaffirming the basics of safe gun handling and storage and by reminding each individual shooter that he or she is the key to firearms safety. You can help meet this responsibility by enrolling in hunter safety or shooting safety courses. You must constantly stress safety when handling firearms, especially to children and non-shooters. Newcomers in particular must be closely supervised when handling firearms with which they may not be acquainted. Don't be timid when it comes to gun safety. If you observe anyone violating any safety precautions, you have an obligation to suggest safer handling practices, such as those in this booklet. Please read these rules carefully and follow the safety procedures outlined. Firearms safety is up to you. Make no mistake about it.

- 1. ALWAYS KEEP THE MUZZLE POINTED IN A SAFE DIRECTION**
- 2. FIREARMS SHOULD BE UNLOADED WHEN NOT ACTUALLY IN USE**
- 3. DON'T RELY ON YOUR GUN'S "SAFETY"**
- 4. BE SURE OF YOUR TARGET AND WHAT'S BEYOND IT**
- 5. USE CORRECT AMMUNITION**
- 6. IF YOUR GUN FAILS TO FIRE WHEN THE TRIGGER IS PULLED, HANDLE WITH CARE**
- 7. ALWAYS WEAR EYE AND HEARING PROTECTION WHEN SHOOTING**
- 8. BE SURE THE BARREL IS CLEAR OF OBSTRUCTIONS BEFORE SHOOTING**
- 9. DO NOT ALTER OR MODIFY YOUR GUN, AND HAVE GUNS SERVICED REGULARLY**
- 10. LEARN THE MECHANICAL AND HANDLING CHARACTERISTICS OF THE FIREARM YOU ARE USING**

*Courtesy of
Sporting Arms and Ammunition Manufacturers' Institute, Inc.*